

# Bio **BRONPI**



serie  
*Alire*

serie  
*hidro*



# LA EMPRESA

Bronpi Calefacción, S.L. es una empresa española ubicada en Lucena (Córdoba) que cuenta con más de 30 años de experiencia en el sector.

Actualmente cuenta con unas instalaciones dotadas con la última tecnología en fabricación e I+D+i, y una plantilla de más de 200 personas que cada día se ponen en marcha para ofrecer la mejor atención y servicio profesional a la red de distribuidores Bronpi.

Con uno de los catálogos más completos del sector, Bronpi Calefacción se posiciona como líder en la fabricación de productos para calefacción doméstica y energías renovables en más de 20 países del mundo, pudiendo encontrar los más de 300 productos que forman su catálogo en los hogares de todo el mundo.

Bronpi Calefacción, S.L. is a Spanish company located in Lucena (Córdoba) that has over 30 years of experience in the sector.

Currently, the company has facilities equipped with the latest technology in manufacturing and R&D+i, and a staff of more than 200 people that each day progress to provide Bronpi dealers with the best professional and personal service.

With one of the most complete catalogs of the sector, Bronpi Calefacción is the leader in the manufacture of products for domestic heating and renewable energies in more than 20 countries worldwide and more than 300 products form its catalog which can be found in homes around the world.

BRONPI Calefacción, S.L. é uma empresa espanhola localizada em Lucena (Córdoba), que tem mais de 30 anos de experiência no setor.

Atualmente, a empresa tem instalações equipadas com a última tecnologia em fabricação e I+D+i, e uma equipe de mais de 200 pessoas que cada dia se esforçam para oferecer o melhor serviço profissional e personalizado a toda a rede de distribuidores Bronpi.

Com um dos catálogos mais completos do setor, BRONPI Calefacción é líder na fabricação de produtos para aquecimento doméstico e energias renováveis em mais de 20 países em todo o mundo e mais de 300 produtos formam seu catálogo que pode ser encontrado em casas em todo o mundo.

## THE COMPANY | A EMPRESA



# CERTIFICACIONES

Bronpi Calefacción cuenta con la certificación ISO 9001 de calidad en la gestión en sus diferentes departamentos.

El compromiso con el control de calidad lleva a Bronpi a crear su propio laboratorio de investigación en el que todos los equipos son probados y desarrollados por el departamento de I+D+i, compuesto por un equipo de ingenieros técnicos especializados.

Posteriormente los equipos son testados en laboratorios externos, que avalan los productos Bronpi con los más altos estándares y normativas de calidad europeas.

El principal objetivo del departamento de I+D+i, certificado bajo la norma UNE 166002, es investigar, mejorar e innovar cada día tanto los productos como el proceso de fabricación para ofrecer al cliente un producto tecnológico, eficiente, novedoso y sostenible.

Bronpi Calefacción is ISO 9001 certified for the quality in the management of its various departments.

The commitment to quality control leads Bronpi to create its own research laboratory in which all equipments are tested and developed by the R&D&i, composed by a team of specialized technical engineers.

Later, equipments are tested at laboratories that endorse Bronpi products with the highest standards and European quality standards.

The main objective of the R&D&i, certified under the UNE 166002, is to research, improve and innovate every day both the products and the manufacturing process in order to offer the customer a technological, efficient, innovative and sustainable product.

## CERTIFICATIONS | CERTIFICAÇÕES

Bronpi Calefacción conta com a certificação ISO 9001 de qualidade na gestão nos seus diferentes departamentos.

O compromisso com o controle de qualidade levou Bronpi a criar o seu próprio laboratório de investigação onde todos os equipamentos são provados e desenvolvidos pelo departamento de I+D+i, composto por uma equipa de engenheiros técnicos especializados.

Posteriormente os equipamentos são testados em laboratórios externos, que avalizam os produtos Bronpi com os mais altos padrões e normativas de qualidade europeias.

O principal objectivo do departamento de I+D+i, certificado sob a norma UNE 166002, centra-se em investigar, melhorar e inovar cada dia, tanto os produtos como o processo de fabrico para oferecer ao cliente um produto tecnológico, eficiente, moderno e sustentável.







Marcado europeo que acredita que el producto cumple con los requisitos legales y técnicos. European marking that certifies the product complies with the legal and technical requirements. Marcação europeia que acredita que o produto cumpre com os requisitos legais e técnicos.

### EN-14785

Norma Europea para aparatos de calefacción doméstica, alimentados con pellet de madera. European Standard for domestic heating pellet equipments. Norma Europeia para equipamentos de aquecimento doméstico, alimentados com pellet de madeira. Standard europeo per i prodotti di riscaldamento domestico a pellet. Norme européenne pour appareils de chauffage domestique à pellet.

### EN-12809

Norma Europea para calderas domésticas independientes que utilizan combustible sólido. Potencia térmica nominal inferior o igual a 50 kW. European Standard for independent domestic boilers using solid fuel. Nominal thermal power of 50 kW or less. Norma Europeia para caldeiras domésticas independentes que utilizam combustível sólido.

### DIN Plus

DINplus: productos conformes a los requisitos de la norma DIN 18891 ampliada, caracterizada por elevados requisitos en materia de protección frente a emisiones. DINplus: Products conform to the requirements of the standard DIN 18891 enlarged, characterized by high requirements for protection against emissions. DINplus: produtos de acordo com as especificações da norma DIN 18891 ampliada, que tem como característica elevados padrões com respeito ao controle de emissões.



Requisitos de diseño ecológico aplicables a calderas y aparatos de calefacción que usen combustibles sólidos. A aplicar a partir del 1 de enero de 2020-2022. Ecodesign requirements for boilers and heating appliances that use solid fuels. To be applied from 1 January 2020-2022. Requisitos de concepção ecológica para caldeiras e aparelhos de aquecimento que utilizam combustíveis sólidos. A vigorar a partir de 1 de Janeiro de 2020-2022.



Marcado francés, que garantiza calidad, eficiencia y alto rendimiento energéticos de los productos de calefacción a leña y a pellet. French Certification ensuring quality, efficiency and high performance of wood and pellet heating products. Marcação francesa, que garante a qualidade, eficiência e alto rendimento energéticos dos produtos de aquecimento a lenha e a pellet.

### I.BimSchV

I.BimSchV: Normativa alemana de protección frente a inmisiones que regula las emisiones para alcanzar los objetivos de protección climática. I.BimSchV: German Standard of protection against immissions regulating emissions to achieve climate protection goals. I.BimSchV: Normativa alemã de proteção referente às emissões, que regula as emissões para alcançar os objetivos de proteção climática.



(Microgeneration Certification Scheme) es una certificación de calidad inglesa que avala los estándares de calidad en el proceso de fabricación de la empresa asegurando al consumidor que el producto se fabrica siempre con la más alta calidad. (Microgeneration Certification Scheme) English quality certification which guarantees quality standards in the manufacturing process of the company assuring consumer that the product is made always with the highest quality. (Microgeneration Certification Scheme) é uma certificação de qualidade inglesa que avaliza os padrões de qualidade no processo de fabrico da empresa, assegurando ao consumidor que o produto é fabricado sempre com a mais alta qualidade.

### EN 303-5

Normativa de eficiencia y emisiones aplicable calderas de calefacción de biomasa (hasta 500 kW). Efficiency and emissions regulation applicable to biomass heating boilers (up to 500 kW). Normativa de eficiência energética e de emissões, aplicável a caldeiras de aquecimento de biomassa (até 500 kw)

### EN-613 (50 Pa)

Norma Europea para aparatos de calefacción doméstica que cumplen con los requisitos para ser estancos. European Standard for domestic heating appliances which meet the requirements to be hermetic. Norma europeia para equipamentos de aquecimento doméstico que cumprem os requisitos para ser estanque.

### 15aB-VG

15a B-VG: Certificación austríaca que regula y comprueba los sistemas de calefacción y ahorro energético. 15a B-VG: Austrian certification regulating and checking heating systems and energetic economies. I.BimSchV: Normativa alemã de proteção referente às emissões, que regula as emissões para alcançar os objetivos de proteção climática. 15a B-VG: Certificação austríaca que regula e comprova os sistemas de aquecimento e poupança energética.



## GARANTÍA WARRANTY | GARANTIA

Los productos Bronpi son fabricados con los más altos requisitos y normativas de fabricación. Es por ello que Bronpi Calefacción, S.L. ofrece una garantía de 2 años o 2400 horas de funcionamiento, todo ello siempre y cuando se hayan cumplido las normas de instalación y uso indicados en el manual de instrucciones. El cristal no está cubierto por la garantía, dado que está homologado para alcanzar temperaturas de hasta 750°C, temperatura que no llega a alcanzar el aparato. Para más información, descargue nuestras condiciones generales de garantía en nuestra web bronpi.com

Bronpi products are manufactured according to the highest standards. For this reason, Bronpi Calefacción, S.L. offers a 2 years or 2400 operating hours warranty, as long as the installation and terms of use indicated in the instruction manual have been fulfilled. The warranty will never cover the break of the glass. This type of glass is certified to withstand a thermal shock up to 750°C and this temperature is not achieved inside the equipment. For further information, download our general warranty conditions on our website bronpi.com

Os produtos Bronpi são fabricados com os mais altos requisitos e normas de fabricação. É por isso que a Bronpi Calefaccion, S.L. oferece uma garantia de 2 anos ou 2400 horas de operação, sempre que se sejam cumpridas as normas de instalação e utilização indicada no manual instruções. O vidro não está coberto pela garantia, visto encontrar-se homologado para atingir temperaturas até 750°C, temperatura que o equipamento não chega a atingir. Para mais informações, descarregue nossas condições gerais de garantia na nossa página (site) da web bronpi.com

## FORMACIÓN TRAINING | FORMAÇÃO

Bronpi pone a disposición de sus distribuidores varios programas de formación técnica impartidos por ingenieros especializados de nuestro departamento técnico y de I+D+i. Los programas son impartidos a lo largo de todo el año en nuestras aulas de formación de Lucena (Córdoba) preparadas especialmente para tal fin. Conocer el funcionamiento de nuestros diferentes productos da un valor añadido tanto a los técnicos encargados de la instalación y el mantenimiento como al personal de ventas que ayudará al usuario final a elegir al producto más adecuado a sus necesidades.

Bronpi offers distributors several technical training programs taught by professional engineers from our technical and R&D+i department. These programs are offered throughout the year in our training rooms in Lucena (Córdoba) prepared specially for this purpose. Knowing how our different products work adds value both to the technicians responsible for the installation and the maintenance as well as to the sales staff who will help the end user to choose the right product according to his needs.

Bronpi põe à disposição dos seus distribuidores vários programas de formação técnica ministrados por engenheiros especializados do nosso departamento técnico e de I+D+i. Os programas são ministrados ao longo de todo o ano no nosso centro de formação em Lucena (Córdoba) preparado especialmente para esse fim. Conhecer o funcionamento dos nossos diferentes produtos, é uma mais-valia tanto para os técnicos encarregados da instalação e da manutenção, como para os encarregados das vendas que irão ajudar o cliente final a escolher o produto mais adequado às suas necessidades.



## ASISTENCIA TÉCNICA TECHNICAL ASSISTANCE | ASSISTÊNCIA TÉCNICA

A lo largo de nuestra larga experiencia y trayectoria como fabricantes, hemos ido creando nuestra propia red de servicios de asistencia técnica para ofrecer al usuario final una atención rápida y eficaz. Los Servicios de Asistencia Técnica Bronpi han sido técnicamente formados y preparados bajo nuestros programas de formación impartidos en Lucena (Córdoba).

Throughout our long experience and career as a manufacturer, we have created our own network of technical assistance services in order to provide the end user with a fast and efficient service. Bronpi Technical Assistance Services are technically trained with our training programs taught in Lucena (Córdoba).

Devido à nossa longa experiência e trajetória como fabricantes, fomos criando a nossa própria rede de Serviços de Assistência Técnica, afim de proporcionar ao cliente final um serviço rápido e eficaz. Os Serviços de Assistência Técnica Bronpi foram tecnicamente formados preparados através dos nossos programas de formação ministrados em Lucena (Córdoba)

## NUEVA WEB DE SERVICIO POST-VENTA NEW WEBSITE FOR AFTER-SALE SERVICE | NOVA PAGINA DE SERVIÇO POS-VENDA

Nuestra nueva web de servicio post-venta bronpiapp.com, le permitirá registrar la garantía y la puesta en marcha de los productos de nuestra marca. Además, en caso necesario, también podrá solicitar asistencia técnica, así como solicitar la visita de uno de nuestros SAT en su zona. Este nuevo servicio desarrollado por Bronpi, le ofrece múltiples ventajas para su empresa como distribuidor:

- Dispondrá de un control exacto de las garantías y puestas en marcha registradas de todos los productos de nuestra marca junto con los datos del usuario final.
- Ahorrará tiempo en las gestiones post-venta, dado que podrá solicitar asistencia técnica y conocer el estado de las solicitudes en tiempo real desde cualquier dispositivo con acceso a Internet.
- Se beneficiará de un servicio post-venta más ágil y eficaz, ya que los datos registrados se conectarán con nuestra central, y nuestros técnicos contarán con una mayor información para ofrecerle soluciones de forma más rápida.

Our new website for after-sale service bronpiapp.com will allow you to register the warranty and the start-up of the products of our brand. In addition, if necessary, you can also request technical assistance, as well as request the visit of one of our Technicians in your area. This new service developed by Bronpi offers multiple advantages for your company as distributor:

- You will have a precise control of the registered warranties and start-ups of all the products of our brand with the end-user data.
- You will save time in the after-sale managements, since it will be able to request technical assistance and to know the status of the requests in real time from any device with access to Internet.
- You will benefit from a more agile and efficient after-sale service, since the registered data will be connected to our head office. Our technicians will have more information in order to offer you much faster solutions.

A nossa nova página web do serviço pós-venda bronpiapp.com, irá permitir o registo da garantia e instalações dos produtos da nossa marca. Além disso, caso seja necessário, também poderá solicitar assistência técnica, assim como solicitar a visita do nosso SAT da Vossa área. Este novo serviço desenvolvido pela Bronpi, oferece múltiplas vantagens, quer para a sua empresa:

- Irá dispor de um controlo rigoroso das garantias e instalações registadas de todos os produtos da nossa marca, conjuntamente com os dados do cliente final.
- Permitirá rentabilizar o tempo na gestão do pós-venda, uma vez que poderá solicitar on-line assistência técnica e informação do estado dos pedidos, a partir de qualquer dispositivo com acesso à Internet.
- Irá beneficiar de um serviço pós-venda mais ágil e eficiente, uma vez que os dados registados serão conectados com a nossa central, o que permite aos nossos técnicos dispor de mais informação, permitindo oferecer soluções de uma forma mais rápida.



# NUESTRA TECNOLOGÍA

## OUR TECHNOLOGIE | NOSSA TECNOLOGIA



**SCL** Sistema Cristal Limpio: sistema que consiste en la entrada de aire del exterior del aparato (secundario) y que es conducido a la cara interna del cristal, mejorando por tanto la combustión e impidiendo que éste se ennegrezca rápidamente, lo que permite una mayor visión del fuego.

Clean Glass System: system based on the air inlet from outside the equipment (secondary) and which is carried to the inner side of the glass, improving the combustion, preventing it from quickly blacken and allowing a greater view of the fire.

Sistema Cristal Limpo: sistema que consiste na entrada de ar do exterior do aparelho (secundário) que é conduzido pela face interna do vidro, melhorando a combustão e impedindo que este fique negro rapidamente, permitindo uma melhor visão do fogo.



**Programable.** El modelo permite ser programado por el usuario para encenderse y apagarse diariamente a las horas indicadas. Además, es posible elegir una programación diferente para días entre semana o días de fin de semana.

**Programmable.** The model can be programmed by the user to switch on and off daily at the indicated times. In addition, it is possible to choose a different schedule for week-days or weekends.

**Programável.** O modelo permite ser programado pelo usuário para ligar e desligar diariamente nas horas escolhidas. Além disso, é possível escolher uma programação distinta para dias da semana ou fim de semana.



**SNC** Sensor de nivel de carga. Gracias a este sistema, el modelo avisará cuando el nivel de combustible en el depósito esté próximo a agotarse.

**Load level sensor.** This system will alert you when the fuel level in the tank is close to deplete.

**Sensor de nível de carga.** Graças a este sistema, o equipamento avisa quando o nível de combustível no depósito está prestes a esgotar-se.



**Sistema de modulación:** a través del cual el modelo modula a diferentes potencias cuando haya alcanzado la temperatura elegida conllevando un importante ahorro en combustible. Incluye sistema StandBy, por el que la estufa se apaga cuando alcanza la temperatura ambiente deseada, y vuelve a encenderse cuando es necesario volver a alcanzar dicha temperatura ambiente.

**Modulation system:** through which the model modulates to different power levels when it has reached the chosen temperature leading to a significant saving in terms of fuel. It includes StandBy system, whereby the stove shuts off when it reaches the desired room temperature, and turns on again when it is necessary to reach that room temperature again.

**Sistema de regulalação:** através do qual o equipamento regula as diferentes potências quando atinge a temperatura escolhida, contribuindo para uma importante poupança de combustível. Inclui sistema StandBy, a salamandra desliga quando chegar a temperatura desejada, e é reiniciada de novo quando é necessário alcançar a referida temperatura.



**SC2** Sistema Doble Cámara: sistema que consiste en la creación de una cámara de aire entre la cámara de combustión y la superficie exterior de la estufa o chimenea, consiguiendo reducir la temperatura superficial del aparato, reduciendo posibles choques térmicos contra paredes, así como crear una convección natural eficiente.

**Double Chamber System:** the double chamber creates an air chamber between the combustion chamber and the outer surface of the stove or fireplace, reducing possible thermal shocks against walls and creating an efficient natural convection.

**Sistema Dupla Câmara:** sistema que consiste na criação de uma câmara de ar entre a câmara de combustão e a superfície exterior do equipamento, levando à redução da temperatura da superfície do aparelho, reduzindo possíveis choques térmicos nas paredes, bem como criar uma convecção natural eficiente.



**Resistencia cerámica.** Encendido más rápido.

**Ceramic resistance.** Turning on quicker. Resistência cerâmica. Acendimento mais rápido.



**Modelo estanco. Ideal para viviendas pasivas.** El producto ha sido diseñado para ser usado en espacios herméticos (construcciones de viviendas pasivas). La cámara de combustión del modelo es perfectamente estanca, permitiendo que pueda funcionar captando el oxígeno exclusivamente desde el exterior, con lo que se reduce el consumo de combustible y aumenta el confort térmico en las casas más modernas, incluso de las de clase A, sin riesgos de emisiones de humo en la sala. Certificada bajo la norma EN-613 de aparatos estancos. Certificada para funcionamiento con tubos concéntricos.

**Hermetic model. Ideal for passive houses.** The product has been designed to be used in hermetic spaces (passive house constructions). The combustion chamber of the model is perfectly airtight, allowing it to operate by taking oxygen exclusively from the outside. This reduces fuel consumption and increases thermal comfort in modern houses, even class A houses, without risk of smoke emissions in the room. Certified under the Standard EN-613 for hermetic appliances. Certified for operation with concentric pipes.

**Modelo estanco. Ideal para casas passivas.** O equipamento foi desenhado para utilização em espaços fechados (construções de vivendas passivas). A câmara de combustão deste modelo é completamente estanque, permitindo que funcione a parte exterior a partir de captura de oxigénio, pelo que o consumo de combustível é reduzido e aumenta o conforto térmico nas casas mais modernas, inclusive as da classe A, sem riscos de emissão de fumo dentro da sala. Certificada pelos padrões da norma EN-613 de equipamentos. Certificada para funcionar com tubos concêntricos.



**Modelo diseñado para un fácil acceso a mantenimientos.**

**Model designed for easy access to maintenance service.**

**Modelo desenhado para uma fácil manutenção técnica.**



**Modelo compatible con KIT WIFI Bronpi,** a través del cual el usuario puede conectarse al aparato desde cualquier punto a través de internet y permitiendo el encendido, apagado, regulación, consulta de estado, etc. (KIT WIFI Opcional). Ver pág. 101.

**Model compatible with KIT WIFI Bronpi,** through which the user can connect to the device from any point through internet, allowing the ignition, switch off, regulation, see the state, etc. (Optional KIT WIFI). See page 101.

**Equipamento compatível com KIT WIFI Bronpi,** através do qual o utilizador pode conectar-se ao equipamento, em qualquer lugar através da internet, permitindo o acendimento, o desligar, a regulação, a consulta de estado, etc. (KIT WIFI Opcional). Consultar pág. 101.



**Modelo compatible con KIT GPRS Bronpi,** a través del cual el usuario puede conectarse al aparato desde cualquier punto a través de un móvil y mensajes SMS, permitiendo el encendido, apagado, regulación, etc. (KIT GPRS Opcional). Ver pág. 101.

**Model compatible with GPRS Bronpi KIT,** through which the user can connect to the device from any point through a mobile and SMS messages, allowing the ignition, switch off, regulation, etc. (Optional GPRS KIT). See page 101.

**Equipamento compatível com KIT GPRS Bronpi,** através do qual o utilizador pode conectar-se ao equipamento, em qualquer lugar e através del telemóvel e mensagens SMS, permitindo o acendimento, o desligar, a regulação, etc. (KIT GPRS Opcional). Consultar pág. 101.



**El nuevo Sistema Independiente de Canalización (SIC) desarrollado por Bronpi** permite: Activar / desactivar el sistema de canalización, optimizando el rendimiento de la estufa de forma que solo se ponga en marcha el sistema de canalización cuando sea necesario. Autorregulación del ventilador auxiliar para la canalización. Selección de la velocidad del flujo de aire canalizado independientemente del nivel de potencia de la estufa.

**The new Independent Channeling System developed by Bronpi** allows: Enable/disable the channeling system, optimizing the performance of the stove so that it only works when necessary. Self-regulation of the auxiliary fan for the channeling. Selection of the speed of the airflow channeled regardless the power level of the stove. O novo sistema independente de canalização desenvolvido pela bronpi permite: Ativar/desativar o sistema de canalização, optimizando o rendimento da salamandra de forma a que só se ponha em funcionamento o sistema de canalização quando for necessário. Auto-regulação do ventilador auxiliar para a canalização. Seleção da velocidade do fluxo de ar canalizado independentemente do nível de potencia da salamandra.



**Silenciosa: posibilidad de desconectar la turbina en todas las potencias.**

**Noiseless: possibility to disconnect the turbine in all power levels.**

**Silenciosa: possibilidade de desconectar a turbina em todas as potências.**

# DOBLE SISTEMA DE LIMPIEZA

## DOUBLE CLEANING SYSTEM | DUPLO SISTEMA DE LIMPIEZA



Este novedoso sistema desarrollado por Bronpi, consiste en el giro de 360° de la base del quemador al mismo tiempo que ésta es limpiada profundamente y de forma automática por un cepillo realizado en acero inoxidable. De esta forma, la limpieza de la base es completa puesto que las cenizas que aún no hayan caído por gravedad al cajón cenicero son barridas por dicho cepillo. Gracias a este sistema, el usuario disfrutará del máximo confort y autonomía del equipo, sin tener que limpiar manualmente el quemador.

This new system developed by Bronpi, consists of the rotation of 360° of the base of the burner at the same time that this base is cleaned in depth and automatically by a high-resistance brush. This will clean the burner base of the ashes that have not yet fallen by gravity into the ashtray drawer. Thanks to this system, the user will enjoy maximum comfort and autonomy of the boiler, without having to clean the burner manually.

Este novo sistema desenvolvido por BRONPI, consta na rotação da base do queimador de 360°, enquanto a base é profundamente e automaticamente limpada por uma escova de alta resistência. Assim, a limpeza da base do queimador é completa já que as cinzas que não tenham caído por gravidade para a gaveta cinzeiro são varridas pela escova. Graças a este sistema, o usuário vai desfrutar do conforto e autonomia da caldeira, sem ter que limpar manualmente o queimador.

# NUEVO DISEÑO DE QUEMADOR

## NEW LAYOUT OF THE BURNER | NOVO SISTEMA DO QUEIMADOR



El nuevo quemador diseñado y desarrollado por Bronpi, supone un importante avance en el ahorro de combustible para el usuario. Este quemador, está elaborado en fundición de alta resistencia y dispone de una base en acero inoxidable inyectado que permite, junto con su diseño cónico, que los inquemados sufran una post-combustión. Este sistema consigue que el aprovechamiento del combustible sea el máximo y uno de los más eficientes del mercado.

The new burner, designed and developed by Bronpi, brings an important advance for the saving of fuel for the user. This burner is made of high resistance cast-iron and has an injected stainless steel base that allows, together with its conical design, a post-combustion of the unburned rests. This system makes the most of the fuel and it is one of the most efficient on the market.

O novo queimador projetado e desenvolvido por BRONPI, é um grande avanço para economizar o combustível. Este queimador é feito de fundição de alta resistência e tem uma base de aço inoxidável injetado permitindo juntamente com a concepção cônica do mesmo, uma pós-combustão dos restos não queimados. Este sistema garante uma maior eficiência no aproveitamento do combustível e é um dos mais eficientes do mercado.

# TECNOLOGÍA OASYS

## OASYS TECHNOLOGY | TECNOLOGIA OASYS

La TECNOLOGÍA OASYS (OPTIMUM AIR SYSTEM) y la TECNOLOGÍA OASYS PLUS son dos novedosos y exclusivos sistemas desarrollados por el departamento de I+D+i de Bronpi Calefacción e incluido en la mayoría de los modelos BioBronpi.

Esta avanzada tecnología controla y analiza los principales factores que inciden en la combustión del pellet para garantizar una perfecta combustión de la misma.

La TECNOLOGÍA OASYS tiene en cuenta factores como:

- Características del pellet: tipo de madera, calidad, densidad, humedad, etc.
- Características de la instalación: longitud total de los tubos, diámetro, codos, curvas, etc.
- Características ambientales: viento, presión atmosférica, altitud sobre el nivel del mar, etc.

Además, la TECNOLOGÍA OASYS PLUS, trabaja de una nueva forma aún más eficiente que mide de manera más concreta estos factores.

Tras detectar y analizar estos factores, automáticamente el equipo se auto-configura en tiempo real, ajustando los parámetros técnicos para optimizar al máximo la combustión del pellet y el funcionamiento del equipo.

Con la TECNOLOGÍA OASYS y la TECNOLOGÍA OASYS PLUS consigue que su equipo BioBronpi esté constantemente adaptado y actualizado a la situación y factores que le rodean.

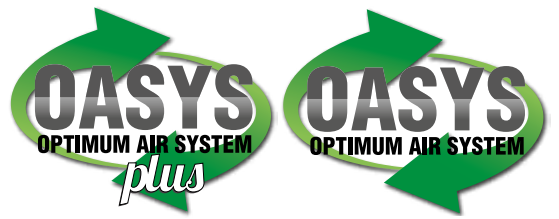

The OASYS TECHNOLOGY (OPTIMUM AIR SYSTEM) and the OASYS PLUS TECHNOLOGY are an innovative and exclusive systems introduced by the Bronpi Calefacción Research, Development & Innovation Department and included in the majority of BioBronpi models.

This modern technology controls and analyzes the main factors of wood burning in order to achieve a perfect combustion.

The OASYS TECHNOLOGY takes different factors into consideration such as:

- Pellet characteristics: kind of wood, quality, density, moisture, etc.
- Installation characteristics: total length of the flue pipes, diameter, bends, curves, etc.
- Ambient characteristics: wind, atmospheric pressure, height above sea level, etc.

In addition, the OASYS PLUS TECHNOLOGY, works in a new more efficient way that measures these factors more concretely.

After detecting and analyzing these factors, the stove automatically self-configures in real time, adjusting technical parameters in order to optimize the pellet combustion and the stove operation.

Thanks to the OASYS TECHNOLOGY and the OASYS PLUS TECHNOLOGY you can be sure that your BioBronpi stove is constantly adapting to the situation and factors around it.

A TECNOLOGIA OASYS (OPTIMUM AIR SYSTEM) e a TECNOLOGIA OASYS PLUS são dois novos e exclusivos sistemas implantados pelo departamento de I+D+i da Bronpi Calefacción.

Esta avançada tecnologia controla e analisa os principais factores que incidem na a combustão do pellet para garantir uma perfeita combustão da mesma. A TECNOLOGIA OASYS tem em conta os seguintes factores como:

- Características do pellet: tipo de madeira, qualidade, densidade, humidade, etc.
- Características da instalação: longitude total dos tubos, diâmetro, curvas, etc.
- Características ambientais: vento, pressão atmosférica, altitude sobre o nível do mar, etc.

Além disso, a TECNOLOGIA OASYS PLUS, funciona de forma mais eficiente, permitindo uma medição mais rigorosa destes fatores.

Permite detectar e analisar estes factores, automaticamente o equipamento se auto-configura em tempo real, ajustando os parâmetros técnicos para otimizar o máximo da combustão do pellet e o funcionamento do equipamento.

Com a TECNOLOGIA OASYS e a TECNOLOGIA OASYS PLUS consegue que o seu equipamento BioBRONPI esteja constantemente adaptado e actualizado à situação e aos factores que a rodeiam.





# TIPOS DE PRODUCTOS

## TYPES OF PRODUCTS | TIPOS DE PRODUTOS

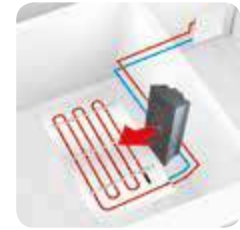

**VENTILACIÓN:** calefacción por aire forzado de los productos que llevan incorporadas turbinas o ventiladores, además de por la propia convección natural.

**VENTILATION:** heating by forced air of the products with turbines or fans, in addition to the natural convection.

**VENTILAÇÃO:** aquecimento através de ar forçado nos equipamentos que incorporam turbinas ou ventiladores, além da sua própria convecção natural.

**HYDRO:** calefacción a través de suelo radiante o radiadores, además de ACS (Agua Caliente Sanitaria) y la calefacción por convección en la habitación donde está instalado el producto

**HYDRO:** heating through underfloor heating or radiators, besides hot water and convection heating in the room where the product is installed.

**HYDRO:** aquecimento através de chão radiante ou radiadores. Produção de AQS (Água Quente Sanitária) e aquecimento por convecção na dependência onde o equipamento está instalado.

**CANALIZACIÓN:** posibilidad de calefactar otras habitaciones contiguas a la habitación donde está instalado el producto mediante la apertura de las salidas de canalización de aire forzado que incluye el producto y el acople de tubos de conducción de aire. (\*)

**CANALIZATION:** possibility of heating other rooms adjacent to the room where the product is installed by opening the forced air canalization outlets included in the product and attaching the air conduction pipes. (\*)

**CANALIZAÇÃO:** possibilidade de aquecer outras dependências contíguas ao local onde está instalado o equipamento, através das saídas de canalização de ar forçado incluído no equipamento acoplado tubos para a condução do ar. (\*)

(\*) La distancia de canalización está estimada con tubo calorifugado del diámetro de la canalización de cada modelo.  
 (\*) The channeling distance is estimated with pipe according to the channeling diameter of each model.  
 (\*) A distância de canalização é estimada com tubo de acordo com o diámetro de canalização de cada modelo.

# SIMBOLOGÍA

## SYMBOLGY | SIMBOLOGIA

kW	kW <sub>≈</sub>	kW <sub>δ</sub>	W	%		
Potencia (kW)	Potencia cedida al aire (kW) max-min	Potencia cedida al agua (kW)	Potencia eléctrica (W)	Rendimiento (%)	Consumo (kg/h)	Autonomía (h) (mín-máx)
Power (kW)	Power transfere to the air (kW) max-min	Power transferred to the water (kW)	Electric power (W)	Efficiency (%)	Consumption (kg/h)	Autonomous (h) (min-max)
Potência (kW)	Potência ce da ao ar (kW) máx-min	Potência cedida á água (kW)	Potência eléctrica (W)	Rendimento (%)	Consumo (kg/h)	Autonomia (h) (mín-máx)
Volumen calefactable (m3)	Interior vermiculita	Interior metálico	Interior fundición	Quemador en fundición	Nº de elementos radiador	Suelo radiante (m²)
Heating capacity (m3)	Vermiculite interior	Metalic inside	Cast-iron inside	Cast-iron burner	Nº radiator elements	Underfloor heating (m²)
Volume de aquecimento(m3)	Interior vermiculite	Interior metálico	Interior fundição	Queimador em fundição	Nº de elementos de radiador	Piso radiante (m²)
	bar <sub>max</sub>	bar				
Ventilación forzada (m³/h)	Presión máxima de trabajo (bar)	Presión de trabajo (bar)	Vaso de expansión cerrado (l)	Temperatura máxima de servicio (°C)	Válvula de vaciado	Bomba circuladora
Forced ventilation (m³/h)	Working maximum pressure (bar)	Working pressure (bar)	Closed expansion vessel (l)	Maximum service temperature (°C)	Valve for drinning water	Water pump
Ventilação forçada (m³/h)	Pressão máxima em funcionamento (bar)	Pressão em funcionamento (bar)	Vaso de expansão fechado (l)	Temperatura máxima de serviço (°C)	Válvula de descarga	Bomba circuladora
	kg					A
Canalizables (diámetro y número de salidas)	Peso(Kg)	Capacidad del depósito (Kg)	Tolva hermética	Diámetro de salida de humos (cm)	Diámetro de aspiración de aire (cm)	Accesorios compatibles no incluidos
Air channelling (diameter and outlet number)	Weight (Kg)	Hopper capacity (Kg)	Hermetic tank	Fume outlet diameter (cm)	Air inlet diameter (cm)	Compatible accessories not included
Tubos (diámetro e número de saídas)	Peso (Kg)	Capacidade do depósito (Kg)	Depósito hermético	Diametro saída de fumos (cm)	Diametro entrada de ar (cm)	Acessórios compatíveis não incluídos

S1	S2	S3
Sistemas de seguridad: -Termostato seguridad pellet -Depresímetro	Sistemas de seguridad: -Termostato seguridad pellet -Termostato seguridad agua -Depresímetro -Válvula seguridad 3 bar- Transductor de presión	Sistemas de seguridad: -Termostato seguridad pellet - Depresímetro -Micro-switch de corte general
Security systems: -Safety thermostat pellet -Air flow switch	Security systems: -Safety thermostat pellet -Safety thermostat water -Air flow switch -Safety valve 3 bar- Pressure setting valve	Security systems: -Safety thermostat pellet -Air flow switch - General break micro-switch
Sistemas de segurança: -Termóstato segurança pellet - Depresímetro	Sistemas de Segurança: -Termóstato segurança pellet -Termóstato segurança água -Depresímetro -Valvula de segurança 3 bar -Transductor de pressão	Sistemas de segurança: -Termóstato segurança pellet -Depresímetro -Micro-switch de corte geral

\* El cálculo de radiadores y suelo se ha determinado, según unas condiciones normales de aislamiento de la vivienda y ubicada en zona templada. Se ha considerado elementos de radiador de aluminio de 60 cm de altura con un salto térmico de 50°, 120 kcal/elemento. Consultar características (potencia) del radiador a utilizar.

\* The calculation of radiators and underfloor heating has been determined according to normal conditions of a house insulation, located in a temperate zone. Aluminium radiator elements have been considered with a height of 60cm and a temperature difference of 50°, 120 kcal/element. Check characteristics (power) of the radiator.

\* O cálculo dos radiadores e do chão radiante foi determinado, tendo por base um isolamento normal da habitação e localizada em zona temperada. Foi usado no cálculo, radiadores de alumínio de 60cm de altura e salto térmico de 50°C 120 kcal/elemento. Consultar características técnicas do radiador a utilizar.





**INSERTABLES** INSERTS | INSERIVEIS  
**10 KW**  
NEVA PAG. 10

**INSERTABLES CANALIZABLES**  
DUCTABLE INSERTS | INSERÍVEIS CANALIZÁVEIS  
**10 KW**  
NEVA-EXTRA PAG. 10

**ESTUFAS** STOVES | SALAMANDRAS  
**7 KW**  
TINA **NOVEDAD** PAG. 12

ELSA 46

**9 KW** PAG. 14

RITA **NOVEDAD**

ZOE **NOVEDAD** 16

NINA **NOVEDAD** 18

KIRA **NOVEDAD** 20

ALBA **NOVEDAD** 22

BERTA **NOVEDAD** 24

**10 KW** PAG. 50

LETICIA 52

DAMA 54

**12 KW** PAG. 54

NOA **NOVEDAD**

PRINCESA **NOVEDAD** 56

**16 KW** PAG. 68

EVA-NC

**ESTUFAS CANALIZABLES**  
DUCTABLE STOVES | SALAMANDRAS CANALIZÁVEIS

**11 KW** PAG. 60

ABRIL-EXTRA **NOVEDAD**

**13 KW** PAG. 62

CARMEN-EXTRA **NOVEDAD**

**16 KW** PAG. 64

LOLA 66

CORAL 68

EVA

**BARBACOA-ESTUFA PELLET**  
PELLET BARBECUE-STOVE | CHURRASQUEIRA PELLET  
**7 KW** PAG. 26  
MAYO **NOVEDAD**

**COCINAS PELLET**  
PELLET COOKER | FOGOE PELLET  
BRENDA **NOVEDAD** 28  
BRENDA-E **NOVEDAD** 30

**ESTUFAS EXTRAPLANAS**  
SUPER-SLIM STOVES | SALAMANDRAS EXTRAPLANAS

**9 KW** PAG. 32

AGATHA 34

ALEXIA 36

ALICIA 44

**12 KW** PAG. 44

CLEO-NC **NOVEDAD**

**EXTRAPLANAS CANALIZABLES**  
DUCTABLE SUPER-SLIMS | EXTRAPLANAS CANALIZÁVEIS

**9 KW** PAG. 38

ALICIA-EXTRA 40

**12 KW** PAG. 42

CLARA-EXTRA 44

OLIVIA-EXTRA

CLEO-EXTRA

**ESTUFA MIXTA LEÑA-PELLET**  
MIXED WOOD-PELLET STOVE | MISTA LENHA-PELLET  
**10 KW** PAG. 48  
CAROL-MIXTA

**HORNO-ESTUFA DE PELLET**  
PELLET OVEN-STOVE | FORNO-SALAMANDRA A PELLET  
**12 KW** PAG. 58  
PAULA **NOVEDAD**

**CONSULTE NUESTRA GAMA DE ACCESORIOS**

SEE OUR RANGE OF ACCESSORIES | VEJA A NOSSA GAMA DE ACESSÓRIOS

PAG. 99-104







NEVA + M-94

Controle su estufa desde cualquier lugar.  
Control your stove from anywhere.  
Controle a sua salamandra a partir de qualquer lugar.  
REF.: KIT WIFI 1

OPCIONAL-OPCIONAL-OPCIONAL

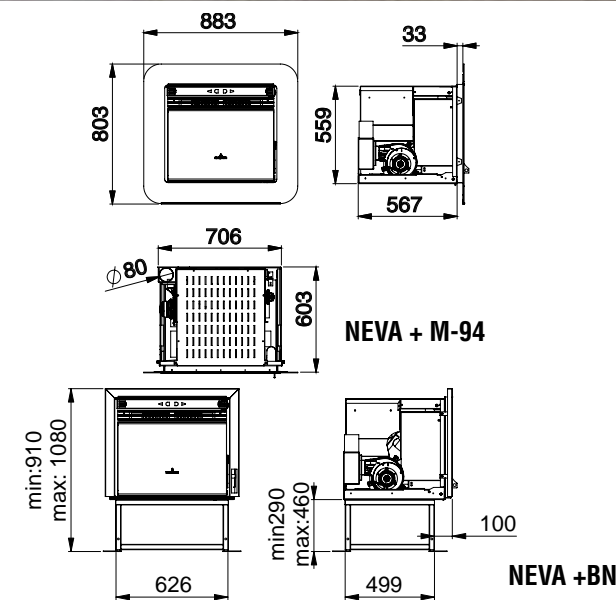

- kW Máx 10,5
- kW 9,3-3,9
- m<sup>3</sup> 232
- % 88-93
- 2,1-0,9 kg/h
- 7,6-17,7 h
- W 150-300 W
- 16 kg
- 1x380 m<sup>3</sup>/h
- Ø 80 mm
- 50 mm
- kg 125
- S1

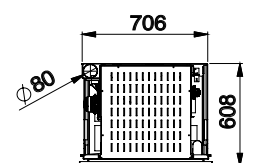
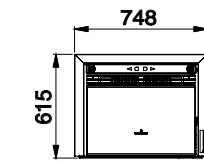
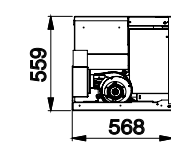

OPCIONAL: KIT-MARCO4-NEVA Perfil inferior del marco para convertirlo a 4 lados  
OPTIONAL: KIT-MARCO4-NEVA Lower profile of the frame to convert it to 4 sides  
OPCIONAL: KIT-MARCO4-NEVA Perfil inferior da moldura para convertê-lo a 4 lados



Mando a distancia incluido.  
Remote control included.  
Comando à distância incluído.

Puerta en cristal vitrocerámico serigrafiado color negro.  
Screen-printed black glass door.  
Porta de vidro vitrocerâmico serigrafada cor preta.

# Neva-Extra

- 1x380 m<sup>3</sup>/h
- 1x130 m<sup>3</sup>/h



9 METROS x 1 SALIDA

80Ø x 1



NEVA EXTRA

Disponibile versión canalizable modelo NEVA-EXTRA  
Ductable version available model NEVA-EXTRA  
Disponível versão canalizável modelo NEVA-EXTRA

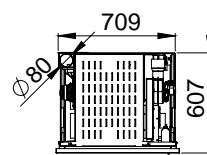
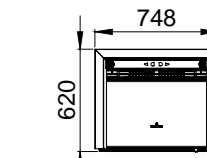
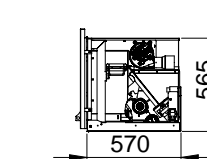
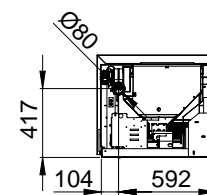



Estufa de pellet  
Pellet stove  
Salamandra a pellet

Tina



TINA-MO

- kW** 7,5
- kW** 6,5-2,5
- m<sup>3</sup>** 163
- %** 87-89
- kg/h** 1,5-0,6
- h** 10,6-26,6
- kg** 16
- m<sup>3</sup>/h** 1x230
- $\varnothing$  80 mm
- 40 mm
- 
- kg** 74
- S1**
- A** KIT M500, KIT M1000

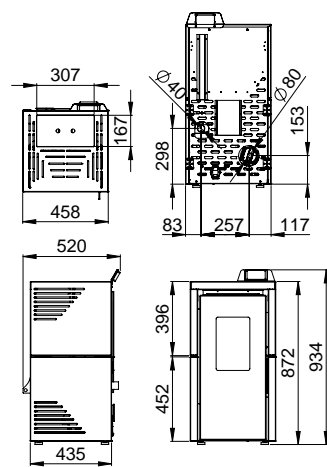

Mando a distancia incluido.  
Remote control included.  
Comando à distância incluído.



Maneta con sistema de cierre patentado por Bronpi. Siempre el ajuste perfecto.  
Handle with locking system patented by Bronpi. Always the perfect fit.  
Puxador com sistema de bloqueio patenteado pela BRONPI. O acabamento sempre perfeito.

Modelo diseñado para un fácil acceso a mantenimientos.  
Model designed for easy access to maintenance service.  
Modelo desenhado para uma fácil manutenção técnica.



TINA-MF



Controle su estufa desde cualquier lugar.  
Control your stove from anywhere.  
Controle a sua salamandra apartir de qualquer lugar.  
REF.: KIT WIFI 1





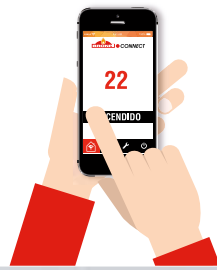

Controle su estufa desde cualquier lugar.  
Control your stove from anywhere.  
Controle a sua salamandra apartir de qualquer lugar.  
REF.: KIT WIFI 1



Puerta, techo y rejilla frontal en fundición.  
Door, top and cast iron frontal grille.  
Porta, tampo e frontal grelha em fundição.



RITA-MF



<b>kW</b> Máx 9,2	1x270 m³/h
<b>kW</b> 8-3	Ø 80 mm
<b>m³</b> 198	40 mm
<b>%</b> 87-90	
1,9-0,7 kg/h	8,5-23 h
<b>W</b> 150-300 W	<b>kg</b> 107
16 kg	<b>S1</b>
	<b>A</b> KIT M500, KIT M1000



Mando a distancia incluido.  
Remote control included.  
Comando à distância incluído.



EN-613: Modelo certificado como estanco.  
EN-613: Model certified as hermetic.  
EN-613: Modelo certificado como estanque.



Maneta con sistema de cierre patentado por Bronpi. Siempre el ajuste perfecto.  
Handle with locking system patented by Bronpi. Always the perfect fit.  
Puxador com sistema de bloqueio patenteado pela Bronpi.  
O acabamento sempre perfeito.

OPCIONAL-OPTIONAL-OPCIONAL

REF.: KIT-C-9

**KIT CANALIZACIÓN | CANALIZATION KIT | KIT CANALIZAÇÃO**

1x130 m³/h  
80Ø x 1  
5 METROS x 1 SALIDA  
SIC

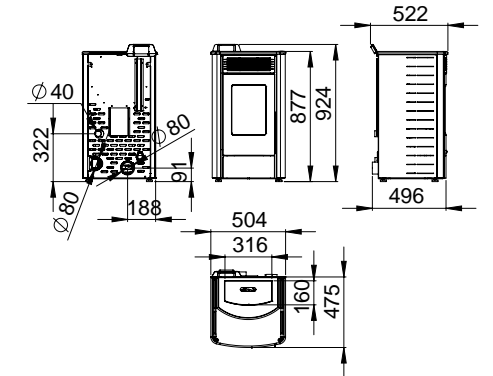

RITA-GR



# Loe





REF.: KIT-C-9  
**KIT CANALIZACIÓN | CANALIZATION KIT | KIT CANALIZAÇÃO**

OPCIONAL-OPCIONAL-OPCIONAL

1x130 m³/h  
 80Ø x 1  
 5 METROS x 1 SALIDA  
 SIC

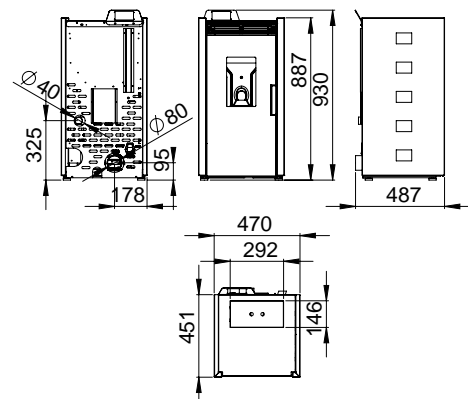
- kW** Máx 9,2
- kW** 8-3
- m³** 198
- %** 87-90
- kg** 1,9-0,7 kg/h
- h** 8,5-23 h
- W** 150-300 W
- kg** 16 kg
- 1x270 m³/h
- Ø 80 mm
- 40 mm
- kg 91
- S1**
- A** KIT M500, KIT M1000



Mando a distancia incluido.  
 Remote control included.  
 Comando à distância incluído.



EN-613: Modelo certificado como estanco.  
 EN-613: Model certified as hermetic.  
 EN-613: Modelo certificado como estanque.



Maneta con sistema de cierre patentado por Bronpi. Siempre el ajuste perfecto.  
 Handle with locking system patented by Bronpi. Always the perfect fit.  
 Puxador com sistema de bloqueio patenteado pela Bronpi.  
 O acabamento sempre perfeito.



ZOE-NE



Controle su estufa desde cualquier lugar.  
 Control your stove from anywhere.  
 Controle a sua salamandra apartir de qualquer lugar.  
 REF.: KIT WIFI 1



ZOE-MF







Controle su estufa desde cualquier lugar. Control your stove from anywhere. Controle a sua salamandra apartir de qualquer lugar.  
REF.: KIT WIFI 1



NINA-MF

<b>kW</b> Máx 9,2	1x270 m³/h
<b>kW</b> 8-3	Ø 80 mm
<b>m³</b> 198	40 mm
<b>%</b> 87-90	
1,9-0,7kg/h	
8,5-23 h	<b>kg</b> 89
<b>W</b> 150-300 W	<b>S1</b>
16 kg	<b>A</b> KIT M500, KIT M1000

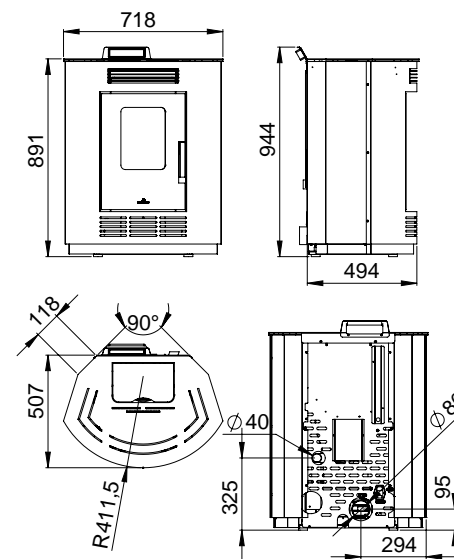

EN-613: Modelo certificado como estanco.  
EN-613: Model certified as hermetic.  
EN-613: Modelo certificado como estanque.



Mando a distancia incluido.  
Remote control included.  
Comando à distância incluído.



Maneta con sistema de cierre patentado por Bronpi. Siempre el ajuste perfecto.  
Handle with locking system patented by Bronpi. Always the perfect fit.  
Puxador com sistema de bloqueio patentado pela Bronpi.  
O acabamento sempre perfeito.



NINA-DO



NINA-MO



NINA-NE





Controle su estufa desde cualquier lugar. Control your stove from anywhere. Controle a sua salamandra apartir de qualquer lugar. REF.: KIT WIFI 1



KIRA-MO

<b>kW</b> Máx 9,2	1x270 m³/h
<b>kW</b> 8-3	Ø 80 mm
<b>m³</b> 198	40 mm
<b>%</b> 87-90	
1,9-0,7 kg/h	
8,5-23 h	<b>kg</b> 89
<b>W</b> 150-300 W	<b>S1</b>
16 kg	<b>A</b> KIT M500, KIT M1000

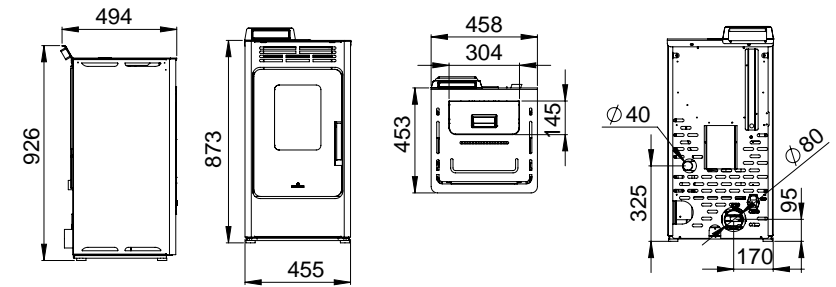

EN-613: Modelo certificado como estanco.  
EN-613: Model certified as hermetic.  
EN-613: Modelo certificado como estanque.



Mando a distancia incluido  
Remote control included  
Comando à distância incluído



Maneta con sistema de cierre patentado por Bronpi. Siempre el ajuste perfecto.  
Handle with locking system patented by Bronpi. Always the perfect fit.  
Puxador com sistema de bloqueio patenteado pela Bronpi. O acabamento sempre perfeito.



KIRA-NE

KIRA-MO

KIRA-CO



KIRA-NA



KIRA-VE



KIRA-AM





Controle su estufa desde cualquier lugar.  
Control your stove from anywhere.  
Controle a sua salamandra apartir de qualquer lugar.  
REF.: KIT WIFI 1



ALBA-MF

- kW** Máx 9,2
- kW** 8-3
- m<sup>3</sup>** 198
- %** 87-90
- kg/h** 1,9-0,7
- h** 8,5-23
- W** 150-300
- kg** 16
- m<sup>3</sup>/h** 1x270
- Ø** 80 mm
- mm** 40
- kg** 79
- S1**
- A** KIT M500  
KIT M1000



REF.: KIT-C-9

KIT CANALIZACIÓN | CANALIZATION KIT | KIT CANALIZAÇÃO



EN-613: Modelo certificado como estanco.  
EN-613: Model certified as hermetic.  
EN-613: Modelo certificado como estanque.

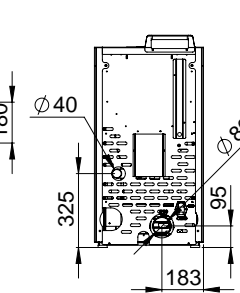
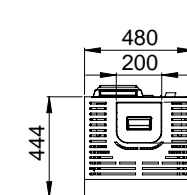
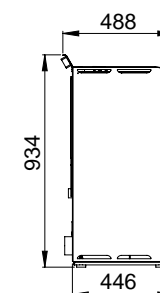
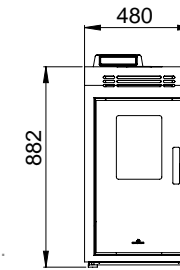

Mando a distancia incluido  
Remote control included  
Comando à distância incluído



Maneta con sistema de cierre patentado por Bronpi. Siempre el ajuste perfecto.  
Handle with locking system patented by Bronpi. Always the perfect fit.  
Puxador com sistema de bloqueio patenteado pela Bronpi. O acabamento sempre perfeito.



ALBA-NE



ALBA-MO



ALBA-CO



ALBA-NA



ALBA-VE



ALBA-AM





<b>kW<sub>Máx</sub></b> 9,2	1x270 m³/h
<b>kW</b> 8-3	Ø 80 mm
<b>m³</b> 198	40 mm
<b>%</b> 87-90	
1,9-0,7 kg/h	
8,5-23 h	<b>kg</b> 89
<b>W</b> 150-300 W	<b>S1</b>
16 kg	<b>A</b> KIT M500 KIT M1000

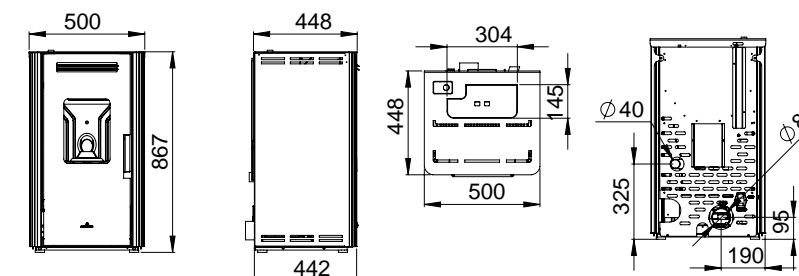

Maneta con sistema de cierre patentado por Bronpi. Siempre el ajuste perfecto.  
Handle with locking system patented by Bronpi. Always the perfect fit.  
Puxador com sistema de bloqueio patenteado pela Bronpi.  
O acabamento sempre perfeito.

EN-613: Modelo certificado como estanco.  
EN-613: Model certified as hermetic.  
EN-613: Modelo certificado como estanque.



- El modelo BERTA dispone de un display de fácil manejo tipo ruleta, que permite encender y apagar la estufa así como controlar la potencia de una forma muy sencilla.  
- BERTA model includes an easy-to-use roulette display that allows to switch on/off the stove as well as controlling the power in a very easy way.  
- O modelo Berta dispõe de um display de fácil manuseamento tipo ruleta que permite acender e apagar a salamandra, bem como controlar a potência de uma forma muito simples.



BERTA-NE



BERTA-MO



BERTA-CO





Estufa-barbacoa-plancha de pellet  
Pellet stove-barbecue-griddle  
Salamandra-churrasqueira-chapa a pellet



MAYO-MF + PROTECTOR MAYO

OPCIONAL | OPTIONAL | OPCIONAL  
**Ref. PROTECTOR-MAYO**  
Panel aislante-protector para puerta.  
Protector-insulating panel for door.  
Painel isolante-protetor para porta.

**USELA COMO BARBACOA INCLUSO CON LA ESTUFA APAGADA(\*)**

USE IT AS A BARBECUE EVEN WHEN THE STOVE IS TURNED OFF(\*)

UTILIZE COMO CHURRASQUEIRA, MESMO COM A SALAMANDRA APAGADA(\*)



(\*)Encendiendo carbón vegetal en su barbacoa.  
(\*)Igniting charcoal in your barbecue.  
(\*)Acendendo a churrasqueira com carvão vegetal.

**Ref. KITB-MAYO**  
Kit barbacoa con parrilla de asados de 390x290 mm. Fácil montaje.  
Barbecue kit with roasting grill of 390x290 mm. Easy assembling.  
Kit churrasqueira com grelha de 390x290 mm. Fácil montagem.



MAYO-MF + HORNO-MAYO + 1 ENCIMERA-MAYO

OPCIONAL | OPTIONAL | OPCIONAL  
**Ref. HORNO-MAYO**  
Módulo horno para cocinar con interior en inox, bandeja inoxidable de 410 x 260 mm y parrilla de asados de 410 x 225 mm. Guías desmontables para facilitar su limpieza. Incluye termómetro de 300° C serigrafado en el cristal para controlar la temperatura.  
Oven module for cooking with stainless steel interior, stainless steel tray of 410 x 260 mm and roasting grill of 410 x 225 mm. Removable tray runners for easy cleaning. Thermometer of 300° C screen printed on the glass for controlling the temperature included.  
Módulo forno para cozinhar com interior em inox, bandeja inox com 410 x 260 mm e grelha para assados com 410 x 225 mm. Com guias desmontáveis para fácil limpeza. Inclui termómetro até 300° C serigrafado no vidro para controle da temperatura.

kW Máx 7,5  
kW 7-4  
m³ 175  
% 91-92  
1,5-0,9 kg/h  
9-15 h  
W 150-300 W  
13,5 kg

1x290 m³/h  
Ø 80 mm  
40 mm  
kg 85  
S1

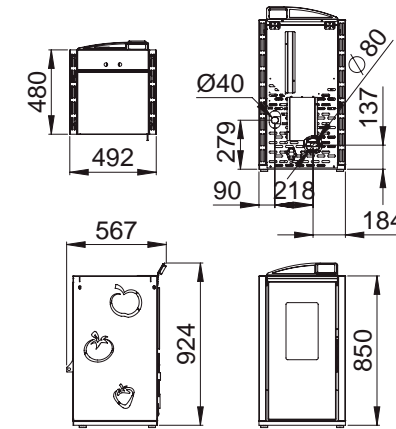

**PUUEE SER USADA COMO COCINA O PLANCHA.**  
IT CAN BE USED AS A KITCHEN OR GRIDDLE.  
PODE SER UTILIZADA COMO CONZINHA OU CHAPA.

Encimera en hierro fundido con esmaltado alimenticio.  
Cast-iron worktop with food enameling.  
Bancada em fundição com esmalte alimenticio.

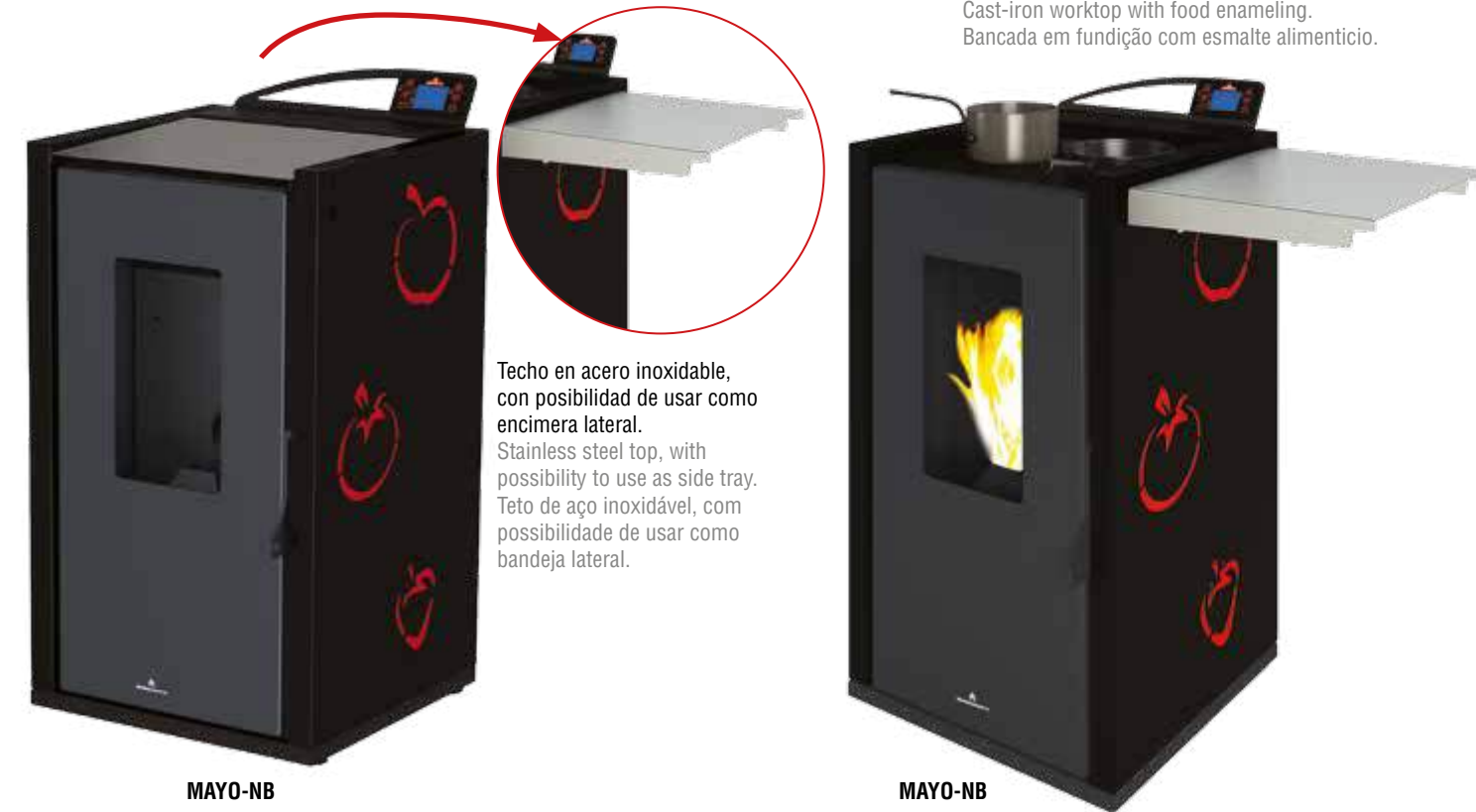

MAYO-NB

MAYO-NB

Techo en acero inoxidable, con posibilidad de usar como encimera lateral.  
Stainless steel top, with possibility to use as side tray.  
Teto de aço inoxidável, com possibilidade de usar como bandeja lateral.



OPCIONAL-OPTIONAL-OPCIONAL  
Controle su estufa desde cualquier lugar.  
Control your stove from anywhere.  
Controle a sua salamandra a partir de qualquer lugar.

REF.: KIT WIFI 1



OPCIONAL | OPTIONAL | OPCIONAL



MAYO-NB + TUBOS-MAYO

**Ref. TUBOS-MAYO**  
Para uso en el exterior. Conexiones para evacuación de humos: codo 90°, 2 tubos, abrazadera y sombrero.  
For use outdoors. Connections for smoke evacuation: 90° elbow, 2 tubes, clamp and cap.  
Para utilização no exterior. Conexões para evacuação de fumo: curva 90°, 2 tubos, abraçadeira e chapéu.



**Ref. RUEDAS-MAYO**  
Kit 4 ruedas para su fácil transporte.  
Kit with 4 wheels for easy transport.  
Kit com 4 rodas para fácil transporte.



**Ref. ENCIMERA-MAYO**  
Encimera lateral adicional en acero inoxidable.  
Additional side countertop in stainless steel.  
Bancada lateral adicional de aço inoxidável.





Controle su estufa desde cualquier lugar.  
Control your stove from anywhere.  
Controle a sua salamandra apartir de qualquer lugar.  
REF.: KIT WIFI 2

OPCIONAL-OPTIONAL-OPCIONAL  
WIFI



BRENDA-BU

- kW Máx 8,6
- kW 7,8-4
- m<sup>3</sup> 195
- % 90-93
- 1,8-0,9 kg/h
- 11,6-23,3 h
- W 150-300 W
- 21 kg
- 1x270 m<sup>3</sup>/h
- Ø 80 mm
- 40 mm
- kg 119
- S1

Posibilidad de salida de humos lateral o trasera.  
Possibility of rear or side smoke outlet.  
Possibilidade de saída de fumos lateral ou traseira.

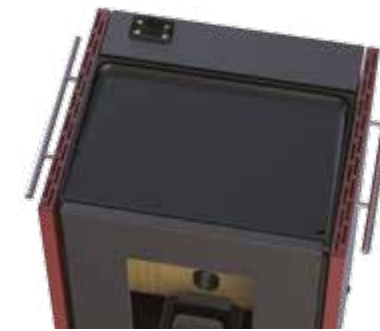
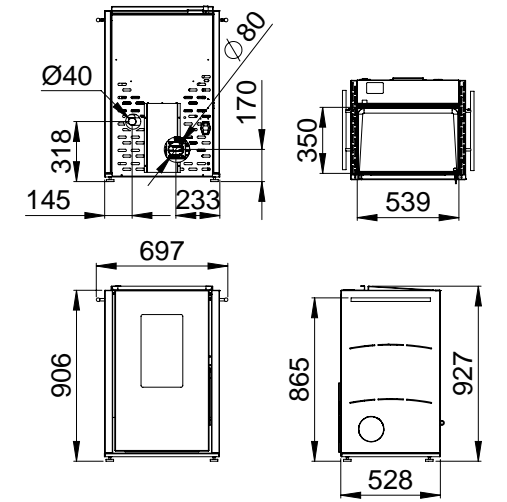

Encimera en hierro fundido con esmaltado alimenticio.  
Puede ser usada como cocina o plancha.  
Cast-iron worktop with food enamelling.  
It can be used as a kitchen or griddle.  
Bancada em fundição com esmalte alimenticio.  
Pode ser utilizada como conzinha ou chapa.



Maneta con sistema de cierre patentado por Bronpi. Siempre el ajuste perfecto.  
Handle with locking system patented by Bronpi. Always the perfect fit.  
Puxador com sistema de bloqueio patenteado pela Bronpi. O acabamento sempre perfeito.



Sistema con depósito recoge-grasas para encimera  
Grease trap system for the worktop.  
Sistema com depósito regolhe-gorduras para bancada.



BRENDA-NE





Posibilidad de salida de humos lateral o trasera.  
Possibility of rear or side smoke outlet.  
Possibilidade de saída de fumos lateral ou traseira.

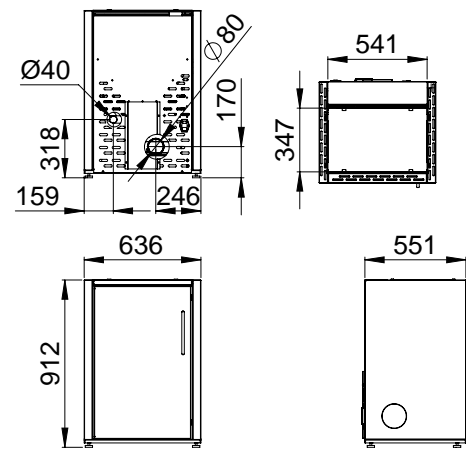

- kW** Máx 8,6
- kW** 7,8-4
- m<sup>3</sup>** 195
- %** 90-93
- 1,8-0,9 kg/h
- 11,6-23,3 h
- W** 150-300 W
- 21 kg
- 1x270 m<sup>3</sup>/h
- 80 mm
- 40 mm
- 
- 
- kg** 127
- S1**

Doble puerta con aislamiento térmico.  
Double door with thermal insulation.  
Porta dupla com isolamento térmico.

Cámaras laterales con aislamiento térmico para poder empotrar.  
Side chambers with thermal insulation with possibility to be inserted.  
Câmaras laterais com isolamento térmico que permitem encastrar.



**BREND A-E-NB**



Encimera en cristal vitrocerámico.  
Ceramic glass worktop.  
Bancada em vidro vitrocerámico.



Display táctil integrado en vitrocerámica.  
Built-in glass ceramic touch display.  
Display tátil integrado em vitrocerámica.

Cocina de pellet para empotrar  
Pellet cooker to be inserted  
Fogoe a pellet para encastrar

# Brenda E



Controle su estufa desde cualquier lugar.  
Control your stove from anywhere.  
Controle a sua salamandra apartir de qualquer lugar.  
REF: KIT WIFI 2



**BREND A-E-MF**







Controle su estufa desde cualquier lugar.  
Control your stove from anywhere.  
Controle a sua salamandra a partir de qualquer lugar.  
REF.: KIT WIFI 1



AGATHA-NE



- kW** Máx 9,3 1x265 m³/h
- kW** 8,5-3,9 Ø 80 mm
- m³** 212 40 mm
- %** 91,1-92,4
- 1,96-0,88 kg/h
- 9-20 h 119 kg
- W** 150-300 W
- 18 kg **S1**

Posibilidad de salida de humos superior, lateral o trasera.  
Possibility of upper, rear or side smoke outlet.  
Possibilidade de saída de fumos superior, lateral ou traseira.



Mando a distancia incluido.  
Remote control included.  
Comando à distância incluído.



Detalle maneta.  
Detail handle.  
Detalhe puxador.



Tapa de carga corredera.  
Sliding cover.  
Tampa de carga movel.

Puerta en cristal vitrocerámico efecto espejo  
Glass-ceramic door with mirror effect.  
Porta de vidro vitrocerâmico efeito espelho.

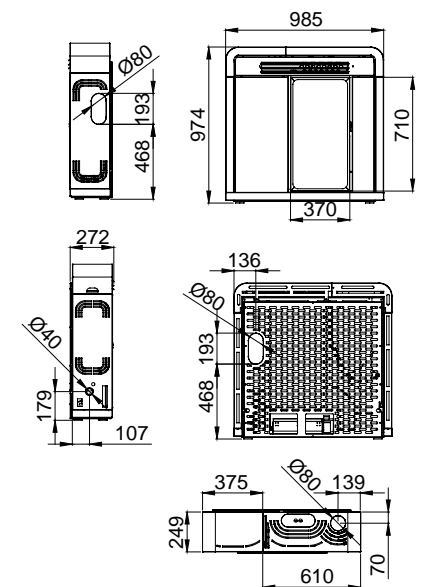

AGATHA-MA







Controle su estufa desde cualquier lugar.  
Control your stove from anywhere.  
Controle a sua salamandra apartir de qualquer lugar.  
REF.: KIT WIFI 1



ALEXIA-MA



- kW** Máx 9,3
- kW** 8,5-3,9
- m<sup>3</sup>** 212
- %** 91,1-92,4
- kg/h** 1,96-0,88
- h** 9-20
- W** 150-300
- kg** 18
- m<sup>3</sup>/h** 1x265
- mm** Ø 80
- mm** 40
- kg** 130
- S1**



Mando a distancia incluido.  
Remote control included.  
Comando à distância incluído.

Posibilidad de salida de humos superior, lateral o trasera  
Possibility of upper, rear or side smoke outlet  
Possibilidade de saída de fumos superior, lateral ou traseira

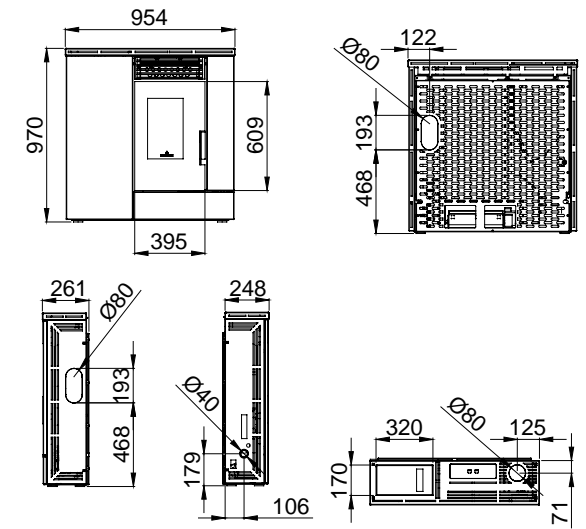

ALEXIA-NE







Controle su estufa desde cualquier lugar.  
Control your stove from anywhere.  
Controle a sua salamandra apartir de qualquer lugar.  
REF.: KIT WIFI 1



ALICIA-DO

- kW** Máx 9,3
- kW** 8,5-3,9
- m<sup>3</sup>** 212
- %** 91,1-92,4
- kg/h** 1,96-0,88
- h** 9-20
- W** 150-300
- kg** 18
- m<sup>3</sup>/h** 1x265
- mm** Ø 80
- mm** 40
- kg** 116
- S1**

Posibilidad de salida de humos superior, lateral o trasera.  
Possibility of upper, rear or side smoke outlet.  
Possibilidade de saída de fumos superior, lateral ou traseira.



Mando a distancia incluido.  
Remote control included.  
Comando à distância incluído.

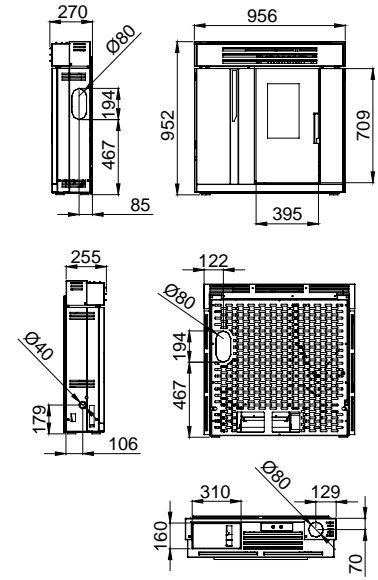

Visión de nivel de carga.  
Load level window.  
Indicação do nível de carga.



ALICIA-NE





Bio BRONPI **Alicia Extra**

9 METROS x 1 SALIDA

CANALIZABLE



Controle su estufa desde cualquier lugar. Control your stove from anywhere. Controle a sua salamandra apartir de qualquer lugar. REF.: KIT WIFI 1



ALICIA-EX-NE



- kW** Máx 9,3
- kW** 8,5-3,9
- m<sup>3</sup>** 212
- %** 91,1-92,4
- kg/h** 1,96-0,88
- h** 9-20
- W** 150-300
- kg** 17
- m<sup>3</sup>/h** 1x265  
1x130
- 80Ø x 1
- Ø 80 mm
- 40 mm
- 130
- S1**

Posibilidad de salida de humos superior, lateral o trasera  
Possibility of upper, rear or side smoke outlet  
Possibilidade de saída de fumos superior, lateral ou traseira

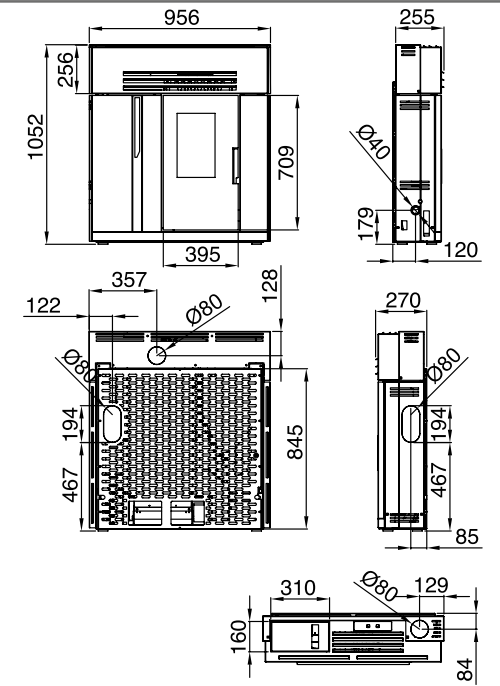

Mando a distancia incluido. Remote control included. Comando à distância incluído.

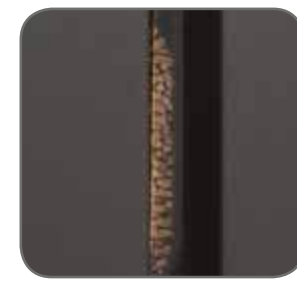

Visión de nivel de carga. Load level window. Indicação do nível de carga.



ALICIA-EX-DO



9 METROS x 2 SALIDAS



CANALIZABLE



Controle su estufa desde cualquier lugar. Control your stove from anywhere. Controle a sua salamandra apartir de qualquer lugar. REF.: KIT WIFI 1



CLARA-EXTRA

**kW** Máx 12,4

80Ø x 2

**kW** 11,3-4,4

Ø 80 mm

**m³** 282

40 mm

**%** 91,4-95,7



**kg/h** 2,5-0,94



**h** 7,2-19



**W** 150-300

**kg** 137

**kg** 18

**S1**

**m³/h** 1x380  
2x130



Mando a distancia incluido. Remote control included. Comando à distância incluído.

Posibilidad de salida de humos superior, lateral o trasera  
Possibility of upper, rear or side smoke outlet  
Possibilidade de saída de fumos superior, lateral ou traseira

Opción de canalización lateral o trasera  
Option of side or rear channelling  
Opção de canalização lateral o traseira

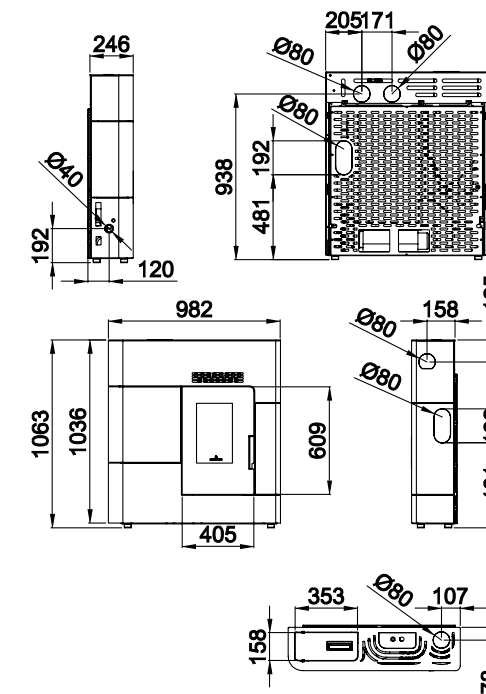

CLARA-EXTRA



9 METROS x 2 SALIDAS

CANALIZABLE



Controle su estufa desde cualquier lugar.  
Control your stove from anywhere.  
Controle a sua salamandra apartir de qualquer lugar.  
REF.: KIT WIFI 1



OLIVIA-EX-OC

Frontales en cristal templado.  
Tempered front glass.  
Painéis frontais de vidro temperado.



kW Máx 12,4

80Ø x 2

kW 11,4-4,4

Ø 80 mm

m<sup>3</sup> 282

40 mm

% 91,4-95,7



2,5-0,94 kg/h



7,2-19 h



W 150-550 W

kg 133

18 kg

S1

1x380 m<sup>3</sup>/h  
2x130 m<sup>3</sup>/h



Mando a distancia incluido.  
Remote control included.  
Comando à distância incluído.



Detalle maneta.  
Detail handle.  
Detalhe puxador.

Posibilidad de salida de humos superior, lateral o trasera  
Possibility of upper, rear or side smoke outlet  
Possibilidade de saída de fumos superior, lateral ou traseira

Opción de canalización lateral o trasera  
Option of side or rear channelling  
Opção de canalização lateral o traseira

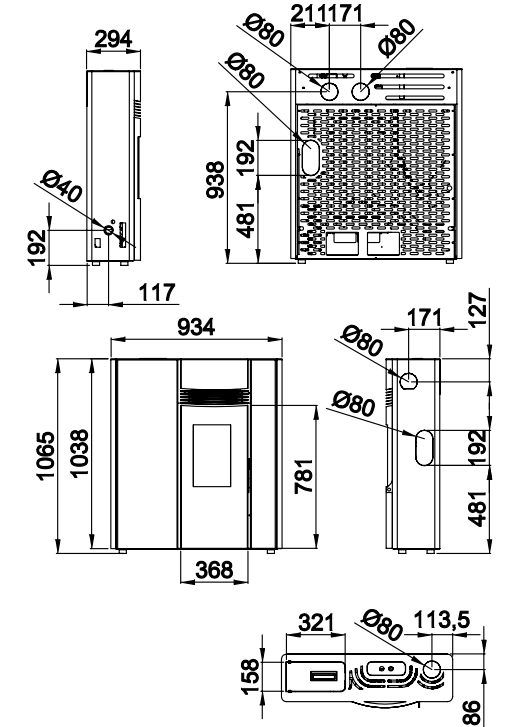

OLIVIA-EX-NE



OLIVIA-EX-RO





# Cleo Extra

9 METROS x 2 SALIDAS



CANALIZABLE



Controle su estufa desde cualquier lugar. Control your stove from anywhere. Controle a sua salamandra apartir de qualquer lugar. REF.: KIT WIFI 1



**CLEO-EX-BL**

Disponible versión no canalizable CLEO-NC-BL  
Non-ductable version available CLEO-NC-BL  
Disponível versão não canalizável CLEO-NC-BL

Frontal en cristal templado.  
Tempered front glass.  
Painel frontal de vidro temperado.



- kW** Máx 12,4
- kW** 11,3-4,4
- m<sup>3</sup>** 282
- %** 91,4-95,7
- 2,5-0,94 kg/h
- 7,2-19 h
- W** 150-550 W
- 18 kg
- 1x380 m<sup>3</sup>/h  
2x130 m<sup>3</sup>/h
- 80Ø x 2
- 80 mm
- 40 mm
- 
- 
- 133
- S1**

Posibilidad de salida de humos superior, lateral o trasera  
Possibility of upper, rear or side smoke outlet  
Possibilidade de saída de fumos superior, lateral ou traseira

Opción de canalización lateral o trasera  
Option of side or rear channelling  
Opção de canalização lateral o traseira

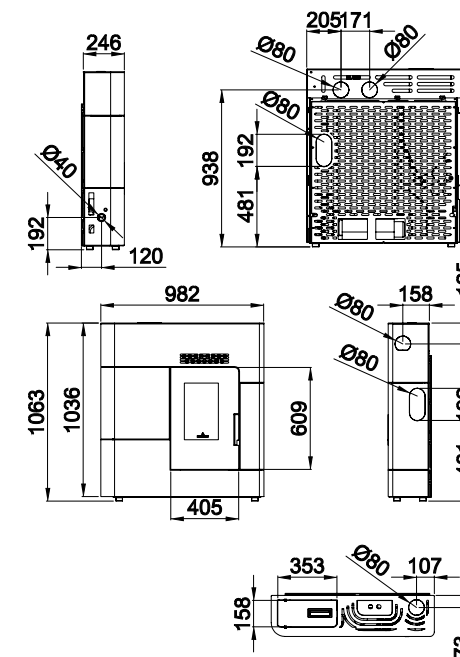

Mando a distancia incluido.  
Remote control included.  
Comando à distância incluído.



Tapa de carga corredera  
Sliding cover  
Tampa de carga movel

# Cleo-NC

Disponible versión no canalizable modelo CLEO-NC  
Non-ductable version available model CLEO-NC  
Disponível versão não canalizável modelo CLEO-NC



1x380 m<sup>3</sup>/h



**CLEO-EX-NE**

Disponible versión no canalizable CLEO-NC-NE  
Non-ductable version available CLEO-NC-NE  
Disponível versão não canalizável CLEO-NC-NE





SILENCIOSA  
NOISELESS  
SILENCIOSA

POSIBILIDAD DE DESCONEJÓN DE LA TURBINA.  
POSSIBILITY OF TURNING OFF THE TURBINE.  
POSSIBILIDADE DE DESCONEJÃO DA TURBINA



- kW** Máx 7,5
- kW** 7-2,4
- m<sup>3</sup>** 175
- %** 95,6-98
- kg/h** 1,5-0,5
- h** 8-25
- W** 150-300
- kg** 12,5
- m<sup>3</sup>/h** 1x450
- mm** Ø 80
- mm** 40
- kg** 175
- S1**

Detalle en acero inoxidable.  
Stainless steel detail.  
Detalhe em aço inoxidável.

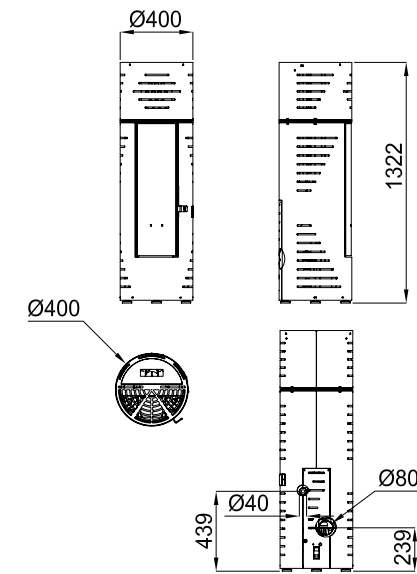

Mando a distancia incluido  
Remote control included  
Comando à distância incluído



Controle su estufa desde cualquier lugar.  
Control your stove from anywhere.  
Controle a sua salamandra apartir de qualquer lugar.

REF.: KIT WIFI 2



Puerta en cristal vitrocerámico curvo serigrafiado color negro.  
Ceramic curved glass door in black.  
Porta vitrocerâmica curva serigrafada cor preta.

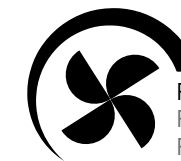

Regulación de la turbina independiente de la potencia de calefacción.  
Regulation of the heating power through the separate turbine.  
Regulação da turbina independente da potência de aquecimento.







Controle su estufa desde cualquier lugar. Control your stove from anywhere. Controle a sua salamandra apartir de qualquer lugar.  
REF.: KIT WIFI 2



	PELLET	LEÑA
<b>kW Máx</b>	10,6	<b>kW</b> 15
<b>kW</b>	9,5-3,0	<b>m³</b> 375
<b>m³</b>	237	<b>%</b> 84
<b>%</b>	92-95,3	<b>h</b> 4,3
<b>h</b>	2,2-0,68	<b>kg</b> 36
<b>h</b>	11-35 h	
<b>W</b>	150-450	
<b>kg</b>	18	

- 1x400 m³/h
- 150 mm
- 40 mm
- 
- 165
- 

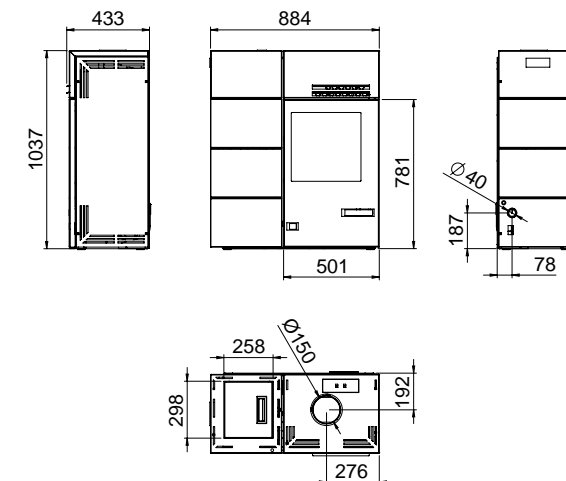

## ¿ESTUFA DE PELLET O DE LEÑA? La respuesta es fácil:

**Carol-Mixta**

El confort y la belleza de un tradicional fuego de leña + La comodidad, tecnología y limpieza del pellet

**ENCENDIDO AUTOMÁTICO**



Parrilla en fundición extraíble para facilitar la limpieza.  
Posibilidad de combinar pellet y leña para su funcionamiento.  
Posibilidad de encendido de leña automático.  
Display retroiluminado para la programación y gestión de la estufa.

Removable cast iron grill for easy cleaning.  
Possibility of combining pellet and firewood for its operation.  
Possibility of automatic ignition of the firewood.  
Backlit display for programming and managing the stove.

Grelha em fundição extraível para fácil limpeza.  
Possibilidade de combinar pellet e lenha para o seu funcionamento.  
Possibilidade de ignição da lenha automática.  
Display retroiluminado para a programação e gestão da salamandra.



**YouTube**

Vea el video explicativo del funcionamiento en nuestro canal de YouTube.

Watch the video explaining the operation on our YouTube channel.

Veja o vídeo explicativo do funcionamento no nosso canal do YouTube.

[youtube.com/BronpiCalefaccion](https://youtube.com/BronpiCalefaccion)







Controle su estufa desde cualquier lugar. Control your stove from anywhere. Controle a sua salamandra apartir de qualquer lugar. REF.: KIT WIFI 1



LETICIA-BU



- kW** Máx 10,5
- kW** 9,5-4,5
- m³** 237
- %** 87-90
- kg/h** 2,1-0,9
- h** 10-23
- W** 150-300
- kg** 21
- 1x450 m³/h
- Ø 80 mm
- 40 mm
- kg 129
- S1

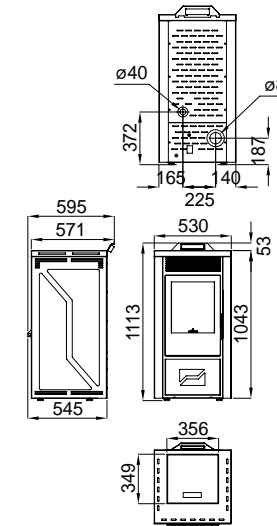

Mando a distancia incluido. Remote control included. Comando à distância incluído.

Puerta en cristal vitrocerámico serigrafiado color negro. Screen-printed black glass door. Porta de vidro vitrocerâmico serigrafada cor preta.



LETICIA-NE



LETICIA-BE





Controle su estufa desde cualquier lugar. Control your stove from anywhere. Controle a sua salamandra a partir de qualquer lugar. REF.: KIT WIFI 1

OPCIONAL-OPTIONAL-OPCIONAL

WIFI



- kW** Máx 10,5
- kW** 9,5-4,5
- m³** 237
- %** 87-90
- kg/h** 2,1-0,9
- h** 10-23
- W** 150-300
- kg** 21
- 1x450 m³/h
- Ø 80 mm
- 40 mm
- kg 122
- S1

Posibilidad de salida de humos lateral o trasera.  
Possibility of rear or side smoke outlet.  
Possibilidade de saída de fumos lateral ou traseira.

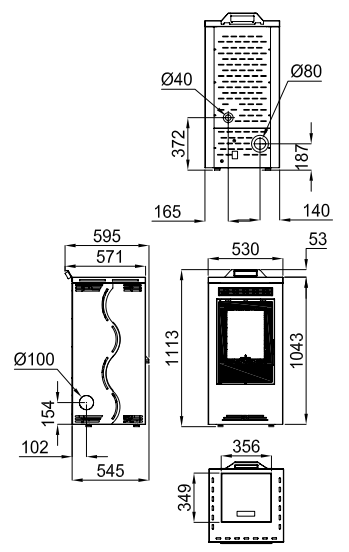

Mando a distancia incluido. Remote control included. Comando à distância incluído.



Puerta en cristal vitrocerámico serigrafiado color negro. Screen-printed black glass door. Porta de vidro vitrocerâmico serigrafada cor preta.



DAMA-BU



DAMA-NE



DAMA-BE





# Noa



OPCIONAL-OPTIONAL-OPCIONAL

1x130 m<sup>3</sup>/h

80Ø x 1

5 METROS x 1 SALIDA

SIC

REF.: KIT-C-12

**KIT CANALIZACIÓN | CANALIZATION KIT | KIT CANALIZAÇÃO**

- kW** Máx 12       1x430 m<sup>3</sup>/h
- kW** 11-4,5       80 mm
-  275       50 mm
- %** 90-93      
-  2,5-1 kg/h      
-  7,6-19 h       135
- W** 150-300 W      **S1**
-  19 kg



Mando a distancia incluido  
Remote control included  
Comando à distância incluído

Incluye intercambiador-acumulador térmico de fundición.  
Includes a cast-iron heat exchanger-accumulator.  
Inclui intercambiador-acumulador térmico em fundição.

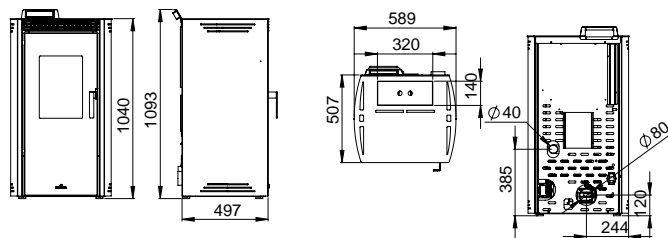

Maneta con sistema de cierre patentado por Bronpi. Siempre el ajuste perfecto.  
Handle with locking system patented by Bronpi. Always the perfect fit.  
Puxador com sistema de bloqueio patentado pela Bronpi. O acabamento sempre perfeito.

OPCIONAL-OPTIONAL-OPCIONAL



**WIFI**

Controle su estufa desde cualquier lugar.  
Control your stove from anywhere.  
Controle a sua salamandra apartir de qualquer lugar.  
REF.: KIT WIFI 1



NOA-NE



NOA-MO

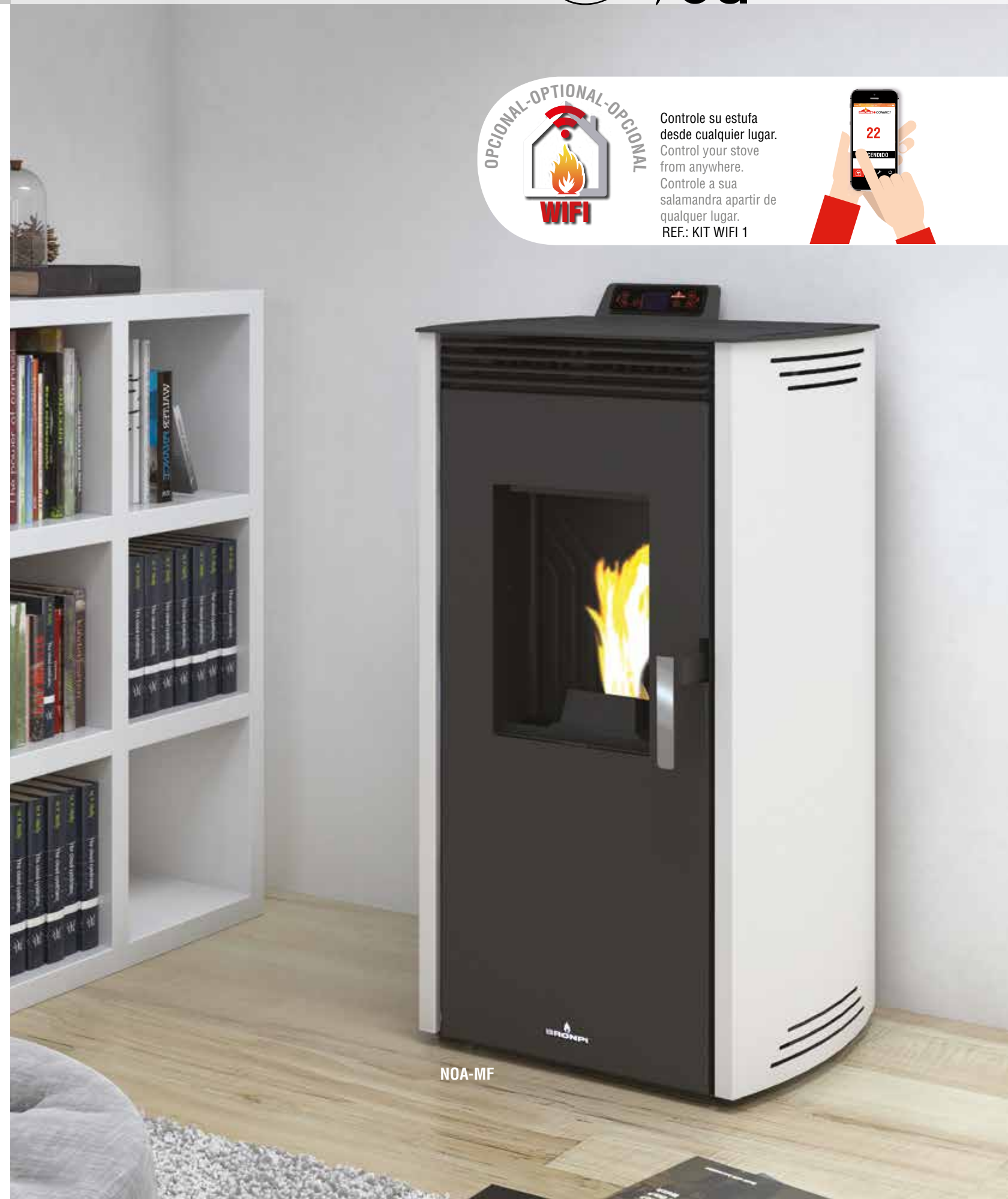

NOA-MF







Controle su estufa desde cualquier lugar. Control your stove from anywhere. Controle a sua salamandra apartir de qualquer lugar.  
REF.: KIT WIFI 1



OPCIONAL-OPCIONAL-OPCIONAL



PRINCESA-BE

- kW** Máx 12
- kW** 11-4,5
- m³** 275
- %** 90-93
- 2,5-1 kg/h
- 7,6-19 h
- W** 150-300 W
- 19 kg
- 1x430 m³/h
- 80 mm
- 50 mm
- 
- 145
- S1**



Mando a distancia incluido. Remote control included. Comando à distância incluido.

Incluye intercambiador-acumulador térmico de fundición. Includes a cast-iron heat exchanger-accumulator. Inclui intercambiador-acumulador térmico em fundição.

Puerta en cristal vitrocerámico serigrafiado color negro. Screen-printed black glass door. Porta de vidro vitrocerâmico serigrafada cor preta.



REF.: KIT-C-12

KIT CANALIZACIÓN | CANALIZATION KIT | KIT CANALIZAÇÃO



Maneta con sistema de cierre patentado por Bronpi. Siempre el ajuste perfecto. Handle with locking system patented by Bronpi. Always the perfect fit. Puxador com sistema de bloqueio patenteado pela Bronpi. O acabamento sempre perfeito.

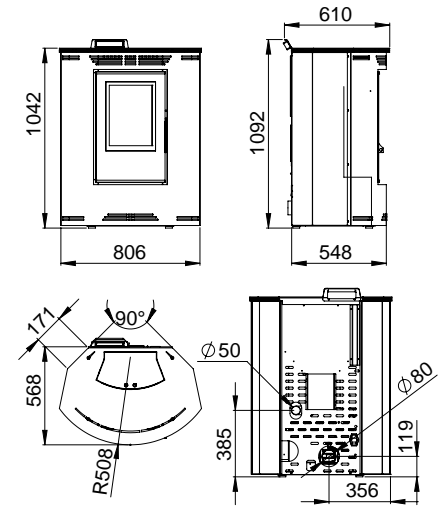

PRINCESA-NE



PRINCESA-BU







PAULA-MF

**DOBLE SISTEMA DE LIMPIEZA**  
Giro 360° de la base del quemador y cepillado.  
Ver pág. 5.  
**DOUBLE CLEANING SYSTEM**  
A 360-degree spin of the base of the burner.  
See page. 5  
**DUPLO SISTEMA DE LIMPEZA**  
Rotação e varrido da base do queimador de 360°.  
Olhar página 5

**OPCIONAL-OPTIONAL-OPCIONAL**  
  
**WIFI**  
Controle su estufa desde cualquier lugar.  
Control your stove from anywhere.  
Controle a sua salamandra a partir de qualquer lugar.  
REF.: KIT WIFI 2

- kW** Max 12,5
- kW** 11,5-5,7
- m³** 313
- %** 92-94
- 2,6-1,2 kg/h
- 7,7-16,6 h
- W** 150-300 W
- 20 kg
- 1x430 m³/h
- $\varnothing$  80 mm
- 50 mm
- 
- 
- kg** 197
- S1**

Regulación de la turbina independiente de la potencia de calefacción.  
Regulation of the heating power through the separate turbine.  
Regulação da turbina independente da potência de aquecimento.

Nuevo diseño del quemador. Máximo ahorro en combustible. Ver pág. 5.  
New layout of the burner. Fuel maximum saving. See page. 5.  
Novo sistema do queimador. Máxima economia em combustível. Olhar página 5

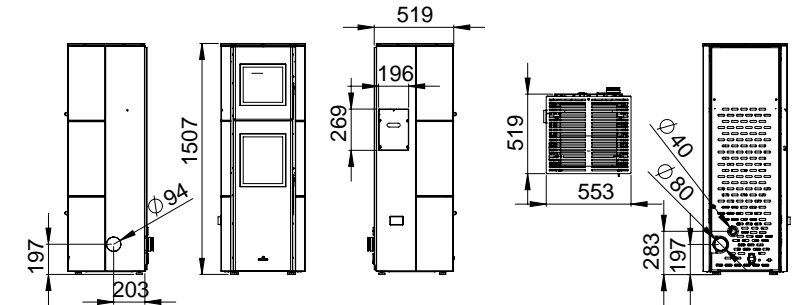

**MODO HORNO-MODO ESTUFA**  
En MODO HORNO, la estufa se autorregula para mantener el horno a la temperatura de cocción elegida por el usuario durante el tiempo que se desee. Por ejemplo, programar el horno a 180°C de cocción durante 30 minutos. Horno con temporizador programable. Tras finalizar el tiempo de cocción elegido por el usuario, la estufa emite un aviso.  
En MODO ESTUFA, la estufa funciona para alcanzar la temperatura ambiente elegida por el usuario, sin tener en cuenta la temperatura de cocción que alcanza el horno.

**MODE OVEN-MODE STOVE**  
With the OVEN MODE, the oven is automatically adjusted to keep the oven at the cooking temperature chosen by the user for the desired time. For example, set the oven to 180°C during 30 minutes. Oven with programmable timer. At the end of the cooking time selected by the user, the stove will alert you.  
With the STOVE MODE, the stove works to reach the ambient temperature chosen by the user, regardless of the cooking temperature reached by the oven.

**MODO FORNO-MODO SALAMANDRA**  
No MODO FORNO, a salamandra regula-se para manter a temperatura de cozedura escolhida do forno pelo usuário durante o tempo desejado. Por exemplo, programar o forno a 180°C por 30 minutos. Forno com temporizador programável. Depois de terminar o tempo de cozimento escolhido pelo usuário, a salamandra avisa.  
No MODO SALAMANDRA, a salamandra funciona para alcançar a temperatura ambiente desejada pelo usuário, independentemente da temperatura de cozedura que chegar o forno.

Posibilidad de salida de humos lateral o trasera.  
Possibility of rear or side smoke outlet.  
Possibilidade de saída de fumos lateral ou traseira.

Cenicero de gran capacidad.  
High capacity ashtray.  
Cinzeiro de grande capacidade.

Puerta en cristal vitrocerámico serigrafiado color negro.  
Screen-printed black glass door.  
Porta de vidro vitrocerâmico serigrafada cor preta.



Sistema de carga lateral.  
Side loading system.  
Sistema lateral de carga.



Horno para asados con base en cerámica para acumular calor e interior en acero inoxidable desmontable para fácil limpieza. Incluye bandeja inox y parrilla cromada.  
Oven for roasting with a ceramic base to accumulate heat and stainless steel interior detachable for an easy cleaning. Includes stainless steel tray and chrome grille.  
Forno para assados, com base em cerâmica para acumulação de calor e interior em aço inoxidável desmontável para uma fácil limpeza. Inclui bandeja em inox e grelha cromada.



PAULA-NE





Controle su estufa desde cualquier lugar.  
Control your stove from anywhere.  
Controle a sua salamandra a partir de qualquer lugar.

REF.: KIT WIFI 1



Nuevo diseño del quemador. Máximo ahorro en combustible. Ver pág. 5.  
New layout of the burner. Fuel maximum saving. See page. 5.  
Novo sistema do queimador. Máxima economia em combustível. Olhar página 5

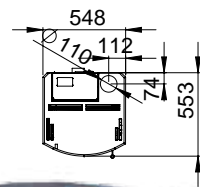
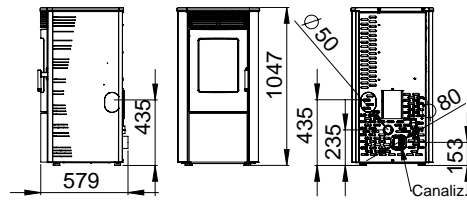

- kW Máx 11
- kW 10-4,5
- m³ 275
- % 91-94
- 2,3-1 kg/h
- 6,9-16 h
- W 150-300 W
- 16 kg
- 1x430 m³/h
- 1x130 m³/h
- 80Ø x 1
- Ø 80 mm
- 50 mm
- kg 160
- S1

Posibilidad de salida de humos superior, lateral o trasera.  
Possibility of upper, side or rear smoke outlet.  
Possibilidade de saída de fumos superior, lateral ou traseira.

Incluye intercambiador-acumulador térmico de fundición.  
Includes a cast-iron heat exchanger-accumulator.  
Inclui intercambiador-acumulador térmico em fundição.

Puerta curva y techo en fundición.  
Curved door and cast iron top.  
Porta curva e tampo em fundição.

Cenicero de gran capacidad.  
High capacity ashtray.  
Cinzeiro de grande capacidade.



Maneta con sistema de cierre patentado por Bronpi. Siempre el ajuste perfecto.  
Handle with locking system patented by Bronpi. Always the perfect fit.  
Puxador com sistema de bloqueio patenteado pela Bronpi. O acabamento sempre perfeito.

ABRIL-EX-NE

5 METROS x 1 SALIDA

CANALIZABLE



**DOBLE SISTEMA DE LIMPIEZA**  
Giro 360° de la base del quemador y cepillado.  
Ver pág. 5.  
**DOUBLE CLEANING SYSTEM**  
A 360-degree spin of the base of the burner.  
See page. 5  
**DUPLO SISTEMA DE LIMPEZA**  
Rotação e varrido da base do queimador de 360°.  
Olhar página 5



ABRIL-EX-MF



SILENCIOSA  
NOISELESS  
SILENCIOSA

POSIBILIDAD DE DESCONEXIÓN DE LA TURBINA.  
POSSIBILITY OF TURNING OFF THE TURBINE.  
POSSIBILIDADE DE DESCONEXÃO DA TURBINA.





### DOBLE SISTEMA DE LIMPIEZA

Giro 360° de la base del quemador y cepillado.  
Ver pág. 5.

### DOUBLE CLEANING SYSTEM

A 360-degree spin of the base of the burner.  
See page. 5

### DUPLO SISTEMA DE LIMPEZA

Rotação e varrido da base do queimador de 360°.  
Olhar página 5



CARMEN-EX-BL

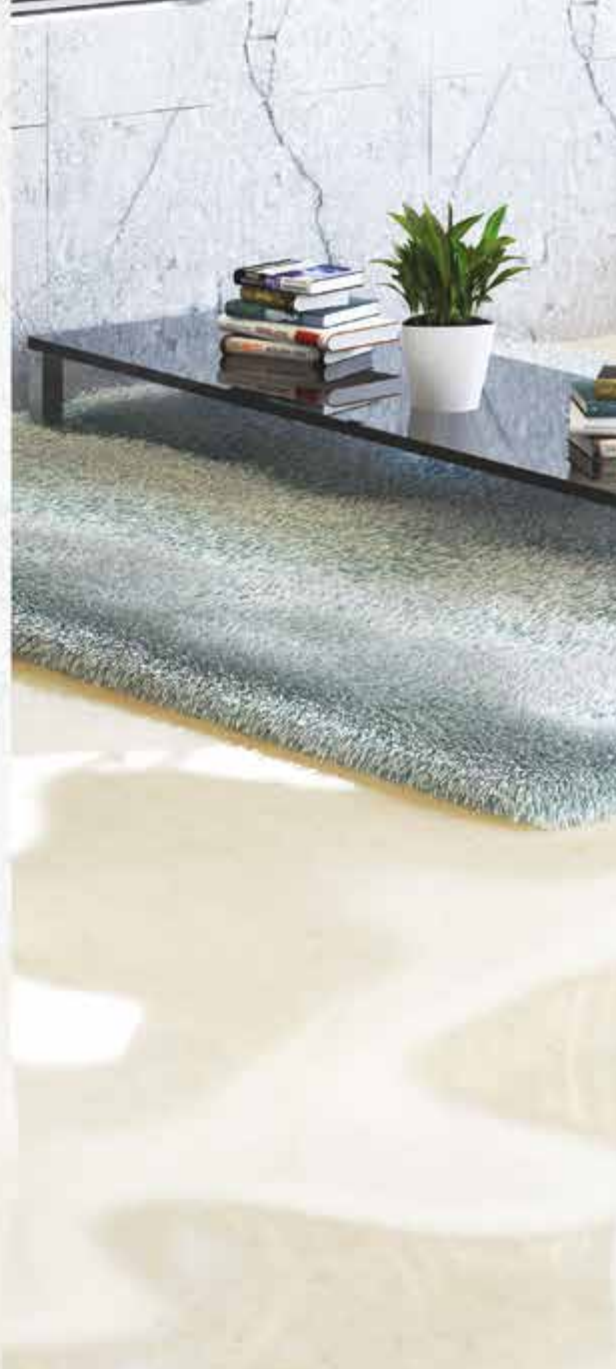

- kW** Máx 13 80Ø x 1
- kW** 12-4,1 Ø 80 mm
- m³** 275 50 mm
- %** 89-94
- 2,7-1 kg/h
- 5,9-16 h
- W** 150-300 W 165
- 16 kg **S1**
- 1x430 m³/h
- 1x130 m³/h



Controle su estufa desde cualquier lugar.  
Control your stove from anywhere.  
Controle a sua salamandra apartir de qualquer lugar.

REF.: KIT WIFI 1



Nuevo diseño del quemador. Máximo ahorro en combustible. Ver pág. 5.  
New layout of the burner. Fuel maximum saving. See page. 5.  
 Novo sistema do queimador. Máxima economia em combustível. Olhar página 5

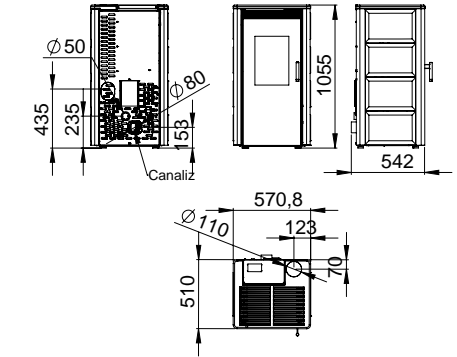

Posibilidad de salida de humos superior o trasera.  
Possibility of upper or side smoke outlet.  
Possibilidade de saída de fumos superior ou traseira.

Incluye intercambiador-acumulador térmico de fundición.  
Includes a cast-iron heat exchanger-accumulator.  
Inclui intercambiador-acumulador térmico em fundição.

Techo en fundición y laterales en cerámica.  
Cast iron top and ceramic sides.  
Tampo em fundição e laterais em cerâmica.

Cenicero de gran capacidad.  
High capacity ashtray.  
Cinzeiro de grande capacidade.



Maneta con sistema de cierre patentado por Bronpi. Siempre el ajuste perfecto.  
Handle with locking system patented by Bronpi. Always the perfect fit.  
Puxador com sistema de bloqueio patenteado pela Bronpi.  
O acabamento sempre perfeito.



CARMEN-EX-NE



9 METROS x 2 SALIDAS



CANALIZABLE



Controle su estufa desde cualquier lugar. Control your stove from anywhere. Controle a sua salamandra apartir de qualquer lugar.  
REF.: KIT WIFI 1



LOLA-MF



kW Máx 16,4

80Ø x 2

kW 14,5-5,3

Ø 80 mm

m³ 362

50 mm

% 90,8-94



3,3-1,2 kg/h



6-16 h



W 150-450 W

kg 154

19 kg

S1

1x430 m³/h  
2x130 m³/h

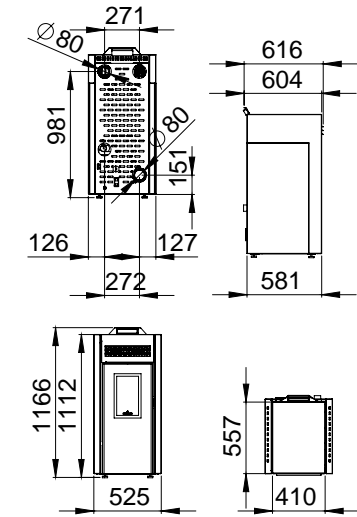

Puerta, lateral y techo en cristal vitrocerámico serigrafiado color negro. Door, side and ceiling in black screen-printed ceramic glass. Porta, lateral e teto de vidro vitrocerâmico serigrafada cor preta.



Mando a distancia incluido. Remote control included. Comando à distância incluído.



Detalle maneta. Detail handle. Detalhe puxador.



Tapa de carga corredera Sliding cover Tampa de carga movel



LOLA-PL



9 METROS x 2 SALIDAS



CANALIZABLE



Controle su estufa desde cualquier lugar. Control your stove from anywhere. Controle a sua salamandra apartir de qualquer lugar. REF.: KIT WIFI 1



CORAL-DO



- kW Máx 16,4
- kW 14,5-5,3
- m<sup>3</sup> 362
- % 90,8-94
- 3,3-1,2 kg/h
- 6-16 h
- W 150-450 W
- 19 kg
- 1x430 m<sup>3</sup>/h  
2x130 m<sup>3</sup>/h
- 80Ø x 2
- Ø 80 mm
- 50 mm
- 154
- S1

Posibilidad de salida de humos lateral o trasera  
Possibility of rear or side smoke outlet  
Possibilidade de saída de fumos lateral ou traseira

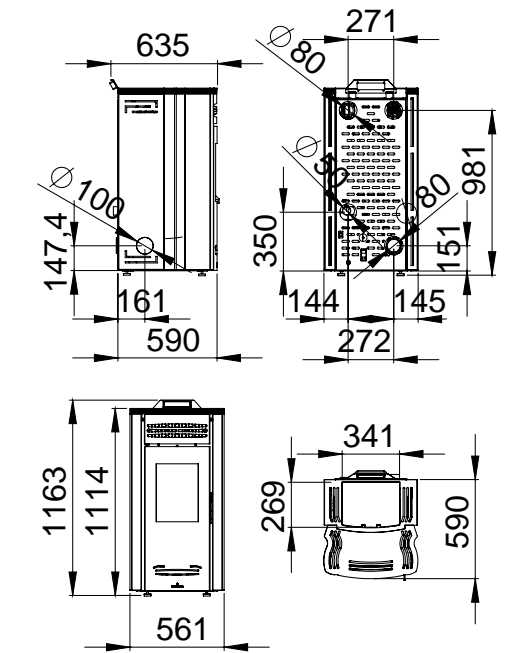

Mando a distancia incluido.  
Remote control included.  
Comando à distância incluido.



CORAL-NE



CORAL-PL



Controle su estufa desde cualquier lugar. Control your stove from anywhere. Controle a sua salamandra a partir de qualquer lugar. REF.: KIT WIFI 1

OPCIONAL-OPTIONAL-OPCIONAL

WIFI

9 METROS x 2 SALIDAS  
CANALIZABLE



EVA



- kW** Máx 16,4
- kW** 14,5-5,3
- m<sup>3</sup>** 362
- %** 90,8-94
- kg/h** 3,3-1,2
- h** 6-16
- W** 150-450
- kg** 19
- m<sup>3</sup>/h** 1x430  
2x130
- 80Ø x 2
- Ø 80 mm
- 50 mm
- kg 145
- S1

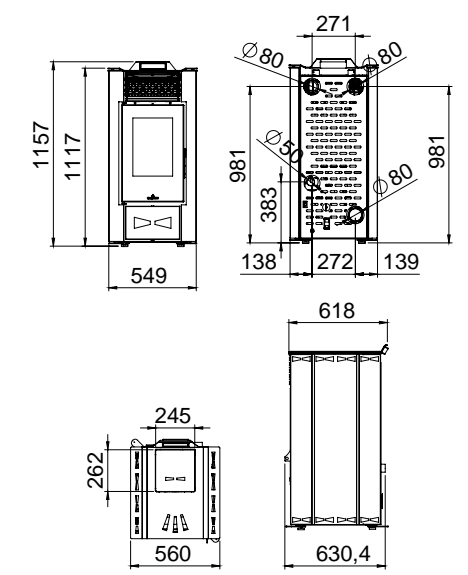

Mando a distancia incluido.  
Remote control included.  
Comando à distância incluído.

# Eva-NC

Disponible versión no canalizable modelo EVA-NC  
Non-ductable version available model EVA-NC  
Disponível versão não canalizável modelo EVA-NC



1x430 m<sup>3</sup>/h



EVA-NC



*Bio* **BRONPI**

seri  
*Hydro*





**INSERTABLES HYDRO**

INSERTS HYDRO | INSERÍVEIS HYDRO

**16 kW**

ALPES HYDRO

PAG.  
74

**TERMOESTUFAS DE PELLET**

PELLET BURNING BACK BOILER  
SALAMANDRAS HIDRO DE PELLET

**16 kW**

LETICIA HYDRO

DAMA HYDRO

**18 kW**

CLARA HYDRO

CLEO HYDRO

**21 kW**

SERIE CARLOTA

PAG.  
76  
78  
PAG.  
80  
82  
PAG.  
84

**CALDERAS DE PELLET**

PELLET BOILERS | CALDEIRAS DE PELLET

**16 kW**

HYDROBOX

**23 kW**

HYDROTEX 23 KW

HYDROCONFORT 23 KW

**27 kW**

HYDROTEX 27 KW

HYDROCONFORT 27 KW

NOVEDAD

NOVEDAD

NOVEDAD

NOVEDAD

PAG.  
86  
PAG.  
88  
PAG.  
90  
PAG.  
88  
90

**CALDERAS MULTIFUEL PELLET+HUESO DE ACEITUNA**

MULTIFUEL BOILERS PELLET+OLIVE STONE  
CALDEIRAS MULTIFUEL PELLET + CAROÇO DE AZEITONA

**21 kW**

HYDROPOLAR-21

HYDROALASKA-21

**27 kW / 34 kW**

HYDROÁRTICA-27

HYDROÁRTICA -34

HYDROBÁLTICA-27

HYDROBÁLTICA-34

92  
94  
92  
94

**CONSULTE NUESTRA GAMA DE ACCESORIOS**

SEE OUR RANGE OF ACCESSORIES | VEJA A NOSSA GAMA DE ACESSÓRIOS

PAG. 99-104





- kW** Máx 16,9
- kW** 15,5-4,7
- kW** ≈ 2-0,4
- kW** <sub>h</sub> 13,5-4,3
- m<sup>3</sup>** 387
- %** 91,7-95,9
- 3,4-0,98 kg/h
- 6,1-21,4 h
- W** 150-400 W
- 21 kg
- 40/80
- 6
- bar** 1,5
- bar** max 2,5
- 96
- 130
- 
- 
- Ø 80 mm
- 50 mm
- 
- 
- 148
- S2**
- A** VAL-02, VAL-04, T-AMP, CRONO-01

Gestión de calefacción y ACS.  
Management of heating and sanitary hot water.  
Gestão do Aquecimento Central e das AQS.

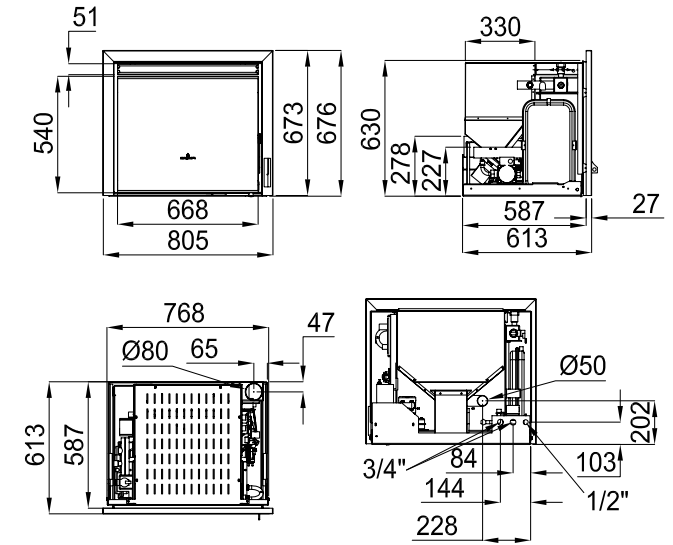

Mando a distancia incluido.  
Remote control included.  
Comando à distância incluido.

Puerta en cristal vitrocerámico serigrafiado color negro.  
Screen-printed black glass door.  
Porta de vidro vitrocerâmico serigrafada cor preta.



ALPES HYDRO



↑ OPCIONAL: KIT-MARCO4-ALPES Perfil inferior del marco para convertirlo a 4 lados  
↑ OPTIONAL: KIT-MARCO4-ALPES Lower profile of the frame to convert it to 4 sides  
↑ OPCIONAL: KIT-MARCO4-ALPES Perfil inferior da moldura para convertê-lo a 4 lados

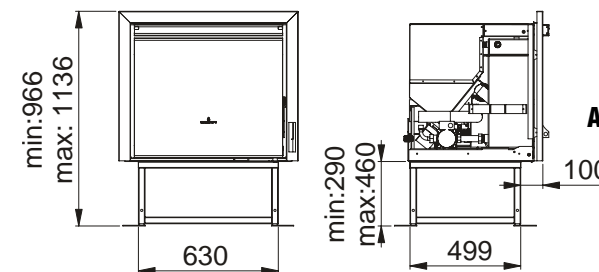

ALPES HYDRO + BA

OPCIONAL | OPTIONAL | OPCIONAL







LETICIA-H-BU

**kW** 16,4  
Máx

**kW** 15-6

**kW** 2,9-1,5

**kW** 12,1-4,5

**m³** 375

**%** 91,9-96,1

**kg/h** 3,3-1,2

**h** 6,4-17,5

**W** 150-300

**kg** 21

**°C** 40/80

**8**

**bar** 1,5

**bar** 2,4  
max

**mm** 82

**mm** 120

**mm**

**mm**

**mm** 80

**mm** 40

**kg**

**kg** 135

**S2**

**A**

VAL-02, VAL-04,  
T-AMP, CRONO-01,  
PE-130



Mando a distancia incluido.  
Remote control included.  
Comando à distância incluído.

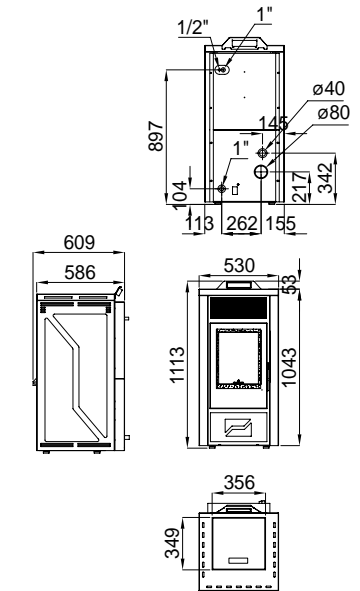

Puerta en cristal vitrocerámico serigrafiado color negro.  
Screen-printed black glass door.  
Porta de vidro vitrocerâmico serigrafada cor preta.



LETICIA-H-NE



LETICIA-H-BE

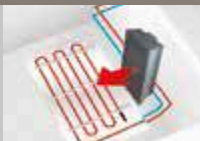





DAMA-H-BE

**kW<sub>Máx</sub>** 16,4  
**kW** 15-6  
**kW<sub>≈</sub>** 2,9-1,5  
**kW<sub>o</sub>** 12,1-4,5  
 375  
**%** 91,9-96,1  
 3,3-1,2 kg/h  
 6,4-17,5 h  
**W** 150-300 W  
 21 kg  
 40/80  
 8

**bar** 1,5  
**bar<sub>max</sub>** 2,4  
 82  
 120  
  
  
 80 mm  
 40 mm  
  
  
**kg** 127  
**S2**

**A** VAL-02, VAL-04,  
T-AMP, CRONO-01,  
PE-130



Mando a distancia incluido.  
Remote control included.  
Comando à distância incluído.

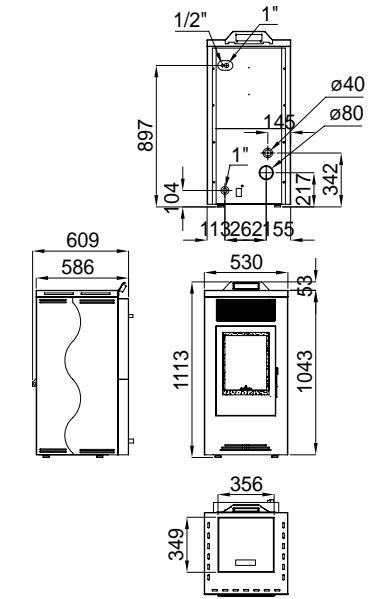

Puerta en cristal vitrocerámico serigrafiado color negro.  
Screen-printed black glass door.  
Porta de vidro vitrocerâmico serigrafada cor preta.



DAMA-H-NE



DAMA-H-BU







CLARA-H

**kW** Máx 18,4

**kW** 17-5

**kW**  $\approx$  2,7-0,3

**kW**  $\circ$  14,2-4,8

**m<sup>3</sup>** 422

**%** 92-96,3

3,7-1,06 kg/h

6,7-23,5 h

**W** 150-400 W

25 kg

40/80

6

**bar** 1,5

**bar** máx 2,5

101

140

80 mm

40 mm

169

**S2**

**A**

VAL-02, VAL-04,  
T-AMP, CRONO-01



Mando a distancia incluido.  
Remote control included.  
Comando à distância incluido.

Posibilidad de salida de humos superior, lateral o trasera  
Possibility of upper, rear or side smoke outlet  
Possibilidade de saída de fumos superior, lateral ou traseira

Gestión de calefacción y ACS.  
Management of heating and sanitary hot water.  
Gestão do Aquecimento Central e das AQS.

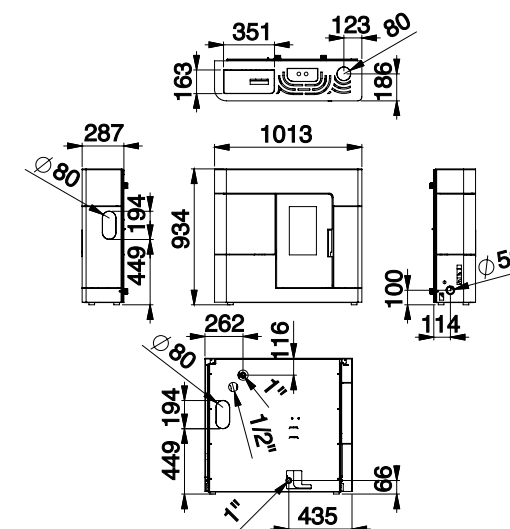

CLARA-H





**kW** Máx 18,4

**kW** 17-5

**kW** ≈ 2,7-0,3

**kW** ∅ 14,2-4,8

**m³** 422

**%** 92-96,3

**kg/h** 3,7-1,06

**h** 6,7-23,5

**W** 150-400

**kg** 25

**°C** 40/80

**6**

**bar** 1,5

**bar** máx 2,5

**mm** 101

**mm** 140

**mm**

**mm**

**mm** ∅ 80

**mm** ∅ 40

**kg**

**kg** 166

**S2**

**A**

VAL-02, VAL-04,  
T-AMP, CRONO-01

Posibilidad de salida de humos superior, lateral o trasera  
Possibility of upper, rear or side smoke outlet  
Possibilidade de saída de fumos superior, lateral ou traseira

Gestión de calefacción y ACS.  
Management of heating and sanitary hot water.  
Gestão do Aquecimento Central e das AQS.

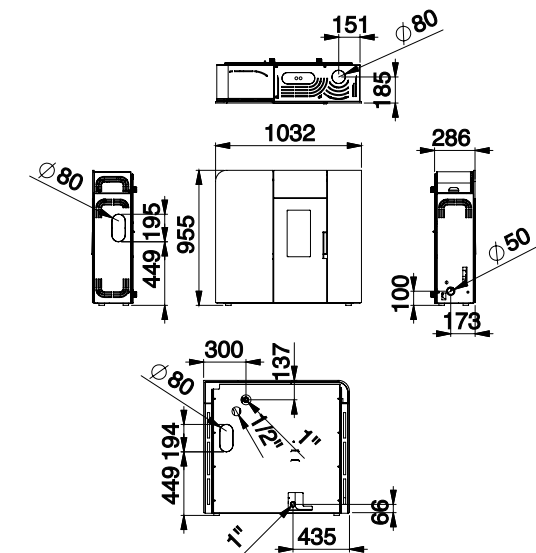

Mando a distancia incluido.  
Remote control included.  
Comando à distância incluido.



Tapa de carga corredera  
Sliding cover  
Tampa de carga movel



CLEO-H-BL

Frontal en cristal templado.  
Tempered front glass.  
Painel frontal de vidro temperado.

CLEO-H-NE





Limpeza totalmente automatizada de intercambiadores y quemador.  
Fully automatic cleaning of exchangers and burner.  
Limpeza totalmente automática dos permutadotes e do queimador.

Gestión de calefacción y ACS.  
Conjunto del soporte y rascadores en acero inox.  
Purgador automático.  
Transductor de presión.  
Cámara aislada térmicamente.

Heating and domestic hot water management.  
Stainless steel support and scrapers.  
Automatic air vent.  
Pressure setting valve.  
Thermally insulated chamber.

Gestão do aquecimento central e das AQS.  
Conjunto do suporte e rascadores em aço inoxidável.  
Purgador automático.  
Transdutor de pressão.  
Câmara isolada térmicamente.

PELLET	HUESO	W	bar <sub>max</sub>
<b>kW<sub>Máx</sub></b> 23,3	<b>kW<sub>Máx</sub></b> 25,4	150-500	2,5
<b>kW</b> 21,2-7,2	<b>kW</b> 23,3	∅ 80 mm	
<b>kW<sub>o</sub></b> 20,3-6,9	<b>kW<sub>o</sub></b> 20,3	60 mm	
<b>m<sup>3</sup></b> 507	<b>m<sup>3</sup></b> 507		
<b>%</b> 91-96	<b>%</b> 92	<b>kg</b> 198 (NE) 205 (MF)	<b>S2</b>
4,9-1,5	5,6	40/80	<b>A</b>
9,8-32 h	9,6	8	VAL-02, VAL-04, T-AMB, CRONO-01, PE-130
48	54	<b>bar</b> 1,5	
145	143		
200	200		

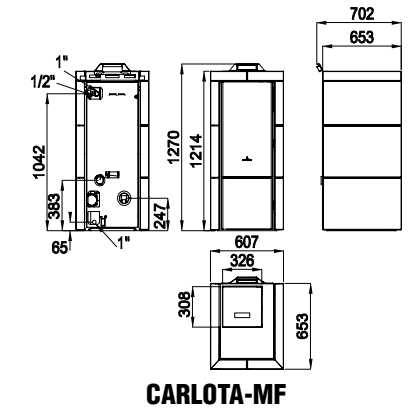

CARLOTA-MF

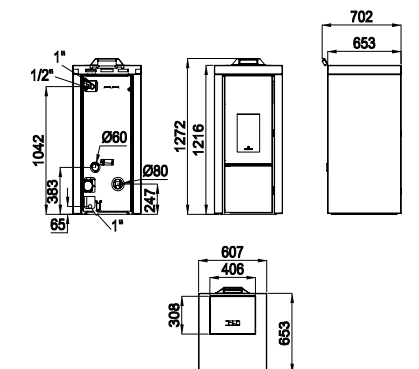

CARLOTA-NE



Mando a distancia incluido.  
Remote control included.  
Comando à distância incluído.



Página 101

Posibilidad de conexión de la tolva a un silo externo  
Possibility of connecting the hopper to an external silo  
Possibilidade de conectar a tremonha a um silo externo

Termoestufa multifuel certificada para pellet y hueso de aceituna  
Multifuel back boiler certified for burning pellet and olive stones  
Termosalamandra multifuel certificada para pellet e carroço de azeitona



CARLOTA-NE







Controle su estufa desde cualquier lugar.  
Control your stove from anywhere.  
Controle a sua salamandra apartir de qualquer lugar.  
REF.: KIT WIFI 2



Sugerencia de instalación en mueble de cocina.  
Suggested installation in kitchen furniture.  
Sugestão de instalação em armário de cozinha.



Sugerencia de carga a través de la encimera.  
Suggested load through the countertop.  
Sugestão de carga a través da bancada.



## MEDIDAS REDUCIDAS IDEAL PARA EMPOTRAR

REDUCED IDEAL MEASURES TO BE INSERTED | MEDIDAS REDUZIDAS IDEAIS PARA ENCASTRAR

Sugerencia de instalación en lavadero / sala de máquinas.  
Installation suggestion in laundry/machine room.  
Sugestão de instalação na lavanderia/sala de máquinas.



- kW** Máx 17
- kW** 16,5-6,5
- kW<sub>h</sub>** 16-6
- m<sup>3</sup>** 395
- %** 90-91
- 3,8-1,5 kg/h
- 7,9-20 h
- W** 150-400 W
- 30 kg
- 40/80
- 6
- bar** 1,5
- bar** máx 2,5
- 113
- 160
- 80 mm
- 40 mm
- 180
- S2**
- A** VAL-02, VAL-04, T-AMP, CRONO-01

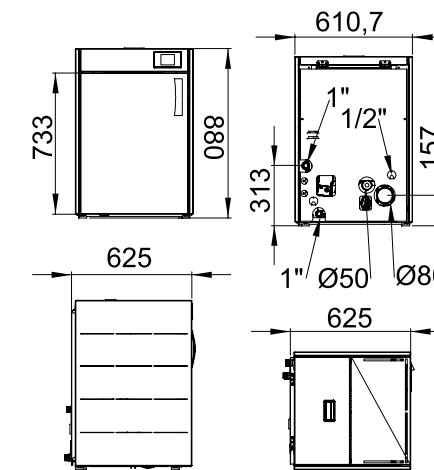

Gestión de calefacción y ACS.  
Management of heating and sanitary hot water.  
Gestão do Aquecimento Central e das AQS.



Grafic LCD Touch en color de 3.5" para programación y gestión de la caldera.  
Graphic LCD color Touch of 3.5" for programming and controlling the boiler.  
Gráfico LCD Touch a cores de 3,5" para a programação e gestão da caldeira.



Nuevo sistema patentado de intercambio térmico. ©  
Capacidad del depósito 46 litros.  
Cámara aislada térmicamente.  
Puerta con interior en vermiculita y visor con doble cristal  
Incluye purgador automático.  
Puerta exterior con aislamiento térmico.

New patented heat exchange system. ©  
46 litres of tank capacity  
Thermally insulated chamber.  
Door with vermiculite interior and viewer with double glass  
Automatic air vent included.  
Exterior door with thermal insulation.

Novo sistema patenteado de troca de calor. ©  
46 litros capacidade do depósito.  
Câmara isolada térmicamente.  
Porta com interior em vermiculita e visor com duplo vidro.  
Purgador automático.  
Porta exterior com isolamento térmico.







Controle su estufa desde cualquier lugar. Control your stove from anywhere. Controle a sua salamandra apartir de qualquer lugar. REF.: KIT WIFI 2



**HYDROTEX 27 + DEPÓSITO DEP-HYDROTEX**



Grafic LCD Touch en color de 3.5" para programación y gestión de la caldera. Grafic LCD color Touch of 3.5" for programming and controlling the boiler. Grafic LCD Touch a cores de 3,5" para a programação e gestão da caldeira.



Gestión de calefacción y ACS. Management of heating and sanitary hot water. Gestão do Aquecimento Central e das AQS.

Nuevo sistema patentado de intercambio térmico. © Cámara aislada térmicamente. Incluye purgador automático.

New patented heat exchange system. © Thermally insulated chamber. Automatic air vent included.

Novo sistema patenteado de troca de calor. © Câmara isolada térmicamente. Purgador automático.

	HydroTex	
	23	27
<b>kW</b>	23	27
<b>kW<sub>o</sub></b>	20-5	26-6
<b>m<sup>3</sup></b>	500	650
<b>%</b>	82-87	82-87
<b>h</b>	4,8-1,2	6,7-1,5
<b>h</b>	12,5-50 h	8,9-40 h
<b>kg</b>	143	186
<b>kg</b>	200	260
<b>kg</b>	60	60

- W** 150-450
- Ø** 100 mm
- mm** 60 mm
- kg** 23→250  
27→275
- °C** 40/80
- 6**
- bar** 1,5
- bar<sub>max</sub>** 3
- S2**
- A** VAL-02, VAL-04, T-AMB, CRONO-01

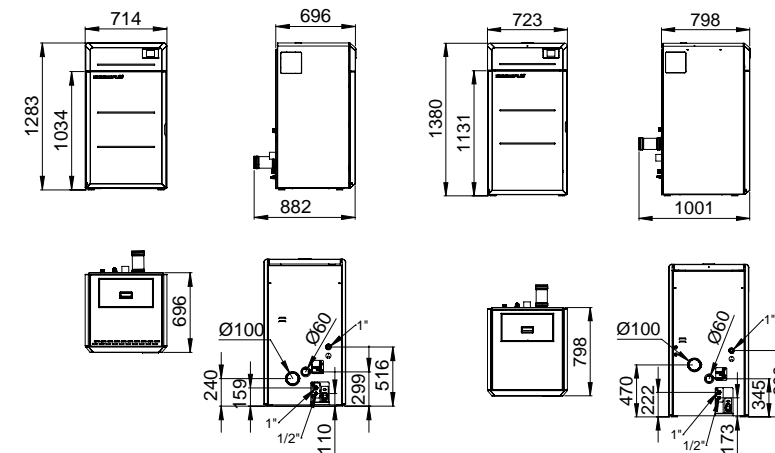

**HYDROTEX 23**

**HYDROTEX 27**

OPCIONAL | OPTIONAL | OPCIONAL

Depósito lateral de carga de 411 litros (260 kg). Posibilidad de instalar a izquierdas o derechas. Side loading tank of 411 litres (260 kg). Possibility of installation either left or right. Depósito lateral de carga de 411 litros (260 kg). Possibilidade de instalar à esquerda ou direita.

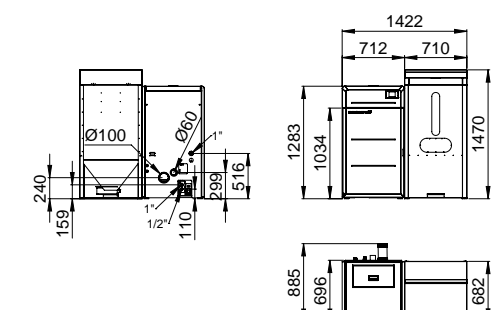

**HYDROTEX 23 + DEPÓSITO DEP-HYDROTEX**

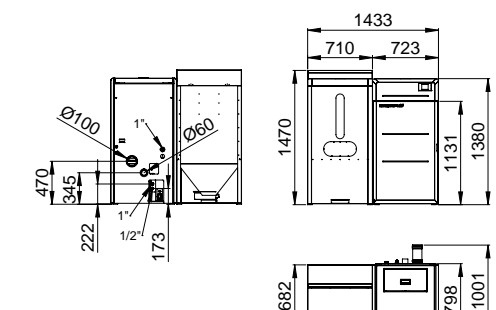

**HYDROTEX 27 + DEPÓSITO DEP-HYDROTEX**





# HydroConfort 23/27



	HydroConfort 23	27
<b>kW</b>	23	27
<b>kW<sub>h</sub></b>	20-5	26-6
<b>m<sup>3</sup></b>	500	650
<b>%</b>	82-87	82-87
<b>Flame</b>	4,8-1,2	6,7-1,5
<b>Hourglass</b>	12,5-50 h	8,9-40 h
<b>Grid</b>	143	186
<b>Coil</b>	200	260
<b>Water</b>	60	60

- W** 150-450
- bar** 1,5
- Ø** 100 mm
- bar<sub>max</sub>** 3
- 60 mm**
- 23→255**
- 27→280**
- kg**
- S2**
- 40/80**
- A** VAL-02, VAL-04, T-AMB, CRONO-01
- 6**



Controle su estufa desde cualquier lugar.  
Control your stove from anywhere.  
Controle a sua salamandra a partir de qualquer lugar.

REF.: KIT WIFI 2

Nuevo diseño del quemador. Máximo ahorro en combustible. Ver pág. 5.  
New layout of the burner. Fuel maximum saving. See page. 5.  
Novo sistema do queimador. Máxima economia em combustível. Olhar página 5

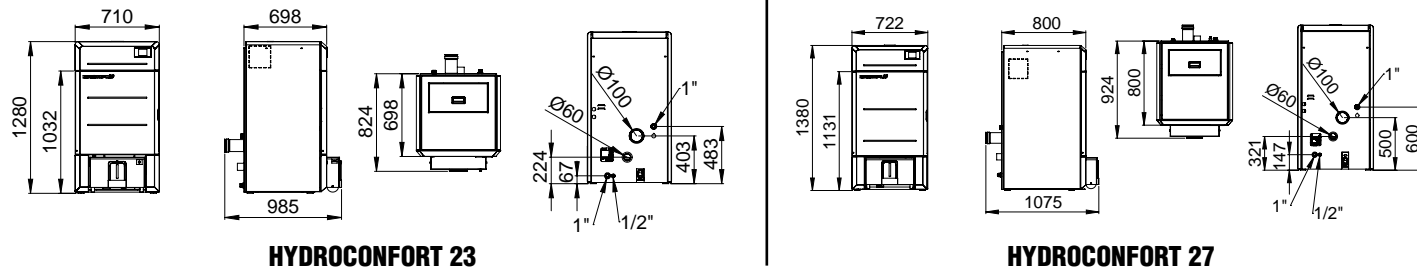

Depósito lateral de carga de 411 litros (260 kg). Posibilidad de instalar a izquierdas o derechas.  
Side loading tank of 411 litres (260 kg). Possibility of installation either left or right.  
Depósito lateral de carga de 411 litros (260 kg). Possibilidade de instalar à esquerda ou direita.

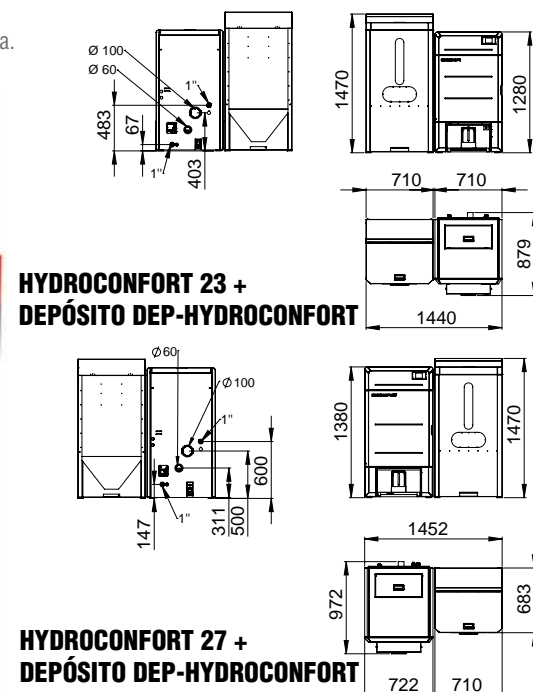

**DOBLE SISTEMA DE LIMPIEZA**  
Giro 360° de la base del quemador y cepillado.  
Ver pág. 5.  
**DOUBLE CLEANING SYSTEM**  
A 360-degree spin of the base of the burner.  
See page. 5  
**DUPLO SISTEMA DE LIMPEZA**  
Rotação e varrido da base do queimador de 360°.  
Olhar página 5

Nuevo sistema patentado de intercambio térmico. ©  
Cámara aislada térmicamente.  
Incluye purgador automático.  
New patented heat exchange system. ©  
Thermally insulated chamber.  
Automatic air vent included.  
Novo sistema patenteado de troca de calor. ©  
Câmara isolada térmicamente.  
Purgador automático.

**HYDROCONFORT 27 + DEPÓSITO DEP-HYDROCONFORT**



Grafic LCD Touch en color de 3,5" para programación y gestión de la caldera.  
Grafic LCD color Touch of 3,5" for programming and controlling the boiler.  
Grafic LCD Touch a cores de 3,5" para programação e gestão da caldeira.



Gestión de calefacción y ACS.  
Management of heating and sanitary hot water.  
Gestão do Aquecimento Central e das AQS.



Sistema compactador de cenizas con cenicero de gran capacidad y visor de nivel de cenizas. Incluye asa y ruedas en el cenicero para fácil transporte.  
Ash compactor system with high capacity ashtray and ash level viewer. Includes handle and wheels in the ashtray for an easy transport.  
Sistema compactador de cinzas com cinzeiro de grande capacidade e visor do nível de cinzas. O cinzeiro inclui pega e rodas para um fácil transporte.





# HydroPolar 21

# HydroÁrtica 27/34



Limpieza totalmente automatizada de intercambiadores y quemador.  
Fully automatic cleaning of exchangers and burner.  
Limpeza totalmente automática dos permutadotes e do queimador.

Conjunto del soporte y rascadores en acero inox.  
Nueva versión del sistema de limpieza del quemador.  
Cámara aislada térmicamente.  
Visor en puerta de cámara de combustión.  
Incluye purgador automático.  
Doble puerta con interior en vermiculita.  
Display LCD retro-iluminado para programación y gestión de la caldera.

Stainless steel support and scrapers.  
New version of the base-cleaning system.  
Thermally insulated chamber.  
Combustion chamber window.  
Automatic air vent included.  
Double door with vermiculite interior.  
LCD Display with light for easy operation in dark room.

Conjunto do suporte e rascadores em aço inoxidável.  
Nova versão do sistema de limpeza do queimador.  
Câmara isolada térmicamente.  
Visor na porta da câmara de combustão.  
Purgador automático.  
Porta dupla com o interior em vermiculite.  
Display LCD com iluminação para programação e gestão da caldeira.



Página 101

Posibilidad de conexión de la tolva a un silo externo  
Possibility of connecting the hopper to an external silo  
Possibilidade de conectar a tremonha a um silo externo



Tapa de carga abatible con sistema neumático para facilitar su apertura y cierre.  
Automatic load cover.  
Tampa de carga rebatível com sistema pneumático para facilitar a sua abertura e fecho.



**HYDROPOLAR 21**  
Capacidad del depósito 74 litros.  
74 litres of tank capacity.  
74 litros capacidade do depósito.

**HYDROARTICA 27/34**  
Capacidad del depósito 154 litros.  
154 litres of tank capacity.  
154 litros capacidade do depósito.



Gestión de calefacción y ACS.  
Management of heating and sanitary hot water.  
Gestão do Aquecimento Central e das AQS.

## PELLET

	HydroPolar 21	HydroÁrtica 27	HydroÁrtica 34
<b>kW Máx</b>	23,3	29,5	37,3
<b>kW</b>	21,2-7,2	27,6-9	34,3-12
<b>kW<sub>o</sub></b>	20,3-6,9	25,7-8	31,4-10,4
<b>m<sup>3</sup></b>	507	642	785
<b>%</b>	91-96	93-96	92-96
<b>h</b>	4,9-1,5	6-1,9	7,6-2,5
<b>h</b>	9,8-32 h	16-53 h	13-40 h
<b>h</b>	145	184	225
<b>h</b>	200	257	314
<b>h</b>	48	98	98

## HUESO

	HydroPolar 21	HydroÁrtica 27	HydroÁrtica 34
<b>kW Máx</b>	25,4	29,5	37,6
<b>kW</b>	23,3	27,6	34,5
<b>kW<sub>o</sub></b>	20,3	25,4	31,3
<b>m<sup>3</sup></b>	507	635	782
<b>%</b>	92	94	92
<b>h</b>	5,6	6,5	8,3
<b>h</b>	9,6 h	17 h	13 h
<b>h</b>	143	182	224
<b>h</b>	200	254	313
<b>h</b>	54	112	112

- W** 150-500
- Ø** 21→80 mm  
27, 34 → 100 mm
- h** 21,27→60 mm  
34→80 mm
- kg** 21→225  
27→293  
34→310
- h** 40/80
- bar** 1,5
- bar<sub>max</sub>** 2,5
- S2**
- A**

VAL-02, VAL-04,  
T-AMB, CRONO-01,  
PE-130

## HYDROPOLAR 21

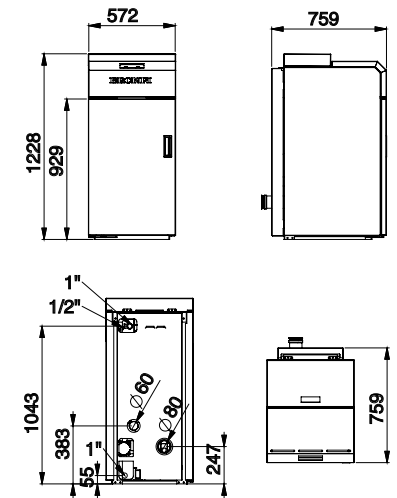

## HYDROARTICA 27/34

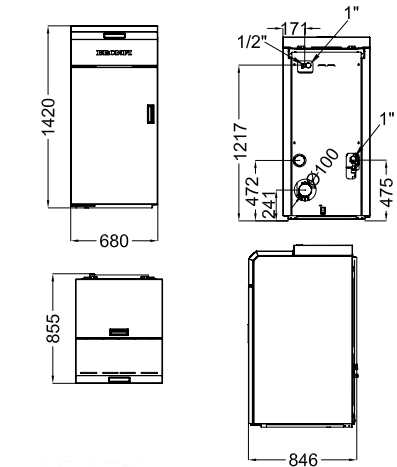

Caldera multifuel certificada para pellet y hueso de aceituna  
Multifuel boiler certified for burning pellet and olive stones  
Caldeira multifuel certificada para pellet e carroço de azeitona



# HydroAlaska 21

# HydroBáltica 27/34



Limpieza totalmente automatizada de intercambiadores y quemador.  
Fully automatic cleaning of exchangers and burner.  
Limpeza totalmente automática dos permutadotes e do queimador.

Conjunto del soporte y rascadores en acero inox.  
Nueva versión del sistema de limpieza del quemador.  
Nuevo sistema de carga del sin-fin.  
Cámara aislada térmicamente.  
Visor en puerta de cámara de combustión.  
Incluye purgador automático.  
Doble puerta con interior en vermiculita.  
Display LCD retro-iluminado para programación y gestión de la caldera.

Stainless steel support and scrapers.  
New version of the base-cleaning system.  
New system of auger load.  
Thermally insulated chamber.  
Combustion chamber window.  
Automatic air vent included.  
Double door with vermiculite interior.  
LCD Display with light for easy operation in dark room.

Conjunto do suporte e rascadores em aço inoxidável.  
Nova versão do sistema de limpeza do queimador.  
Novo sistema de carga do sem fim.  
Câmara isolada térmicamente.  
Visor na porta da câmara de combustão.  
Purgador automático.  
Porta dupla com o interior em vermiculite.  
Display LCD com iluminação para programação e gestão da caldeira.

**HYDROALASKA 21**  
Capacidad del depósito 361 litros.  
361 litres of tank capacity.  
361 litros capacidade do depósito.

**HYDROBALTICA 27/34**  
Capacidad del depósito 615 litros.  
615 litres of tank capacity.  
615 litros capacidade do depósito.

Caldera multifuel certificada para pellet y hueso de aceituna  
Multifuel boiler certified for burning pellet and olive stones  
Caldeira multifuel certificada para pellet e carroço de azeitona



Tapa de carga abatible con sistema neumático para facilitar su apertura y cierre.  
Automatic load cover.  
Tampa de carga rebatível com sistema pneumático para facilitar a sua abertura e fecho.



Gestión de calefacción y ACS.  
Management of heating and sanitary hot water.  
Gestão do Aquecimento Central e das AQS.

## PELLET

	HydroAlaska 21	HydroBáltica 27	HydroBáltica 34
<b>kW<sub>Máx</sub></b>	23,3	29,5	37,3
<b>kW</b>	21,2-7,2	27,6-9	34,3-12
<b>kW<sub>o</sub></b>	20,3-6,9	25,7-8	31,4-10,4
<b>m<sup>3</sup></b>	507	642	785
<b>%</b>	91-96	93-96	92-96
<b>h</b>	4,9-1,5	6-1,9	7,6-2,5
<b>h</b>	9,8-32	16-53	13-40
<b>h</b>	145	184	225
<b>h</b>	200	257	314
<b>h</b>	235	399	399

## HUESO

	HydroAlaska 21	HydroBáltica 27	HydroBáltica 34
<b>kW<sub>Máx</sub></b>	25,4	29,5	37,6
<b>kW</b>	23,3	27,6	34,5
<b>kW<sub>o</sub></b>	20,3	25,4	31,3
<b>m<sup>3</sup></b>	507	635	782
<b>%</b>	92	94	92
<b>h</b>	5,6	6,5	8,3
<b>h</b>	9,6	17	13
<b>h</b>	143	182	224
<b>h</b>	200	254	313
<b>h</b>	259	442	442

**W** 150-500 **bar** 1,5

**Ø** 21→80 mm **bar<sub>max</sub>** 2,5

**h** 21,27→60 mm  
34→80 mm



**kg** 21→268  
27→353  
34→370

**h** 40/80

**h** 8

**bar** 1,5

**bar<sub>max</sub>** 2,5



**S2**

**A**

VAL-02, VAL-04,  
T-AMB, CRONO-01,  
PE-130

## HYDROALASKA 21

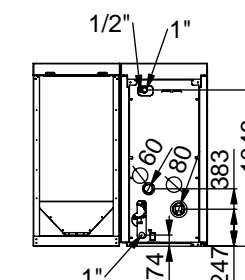
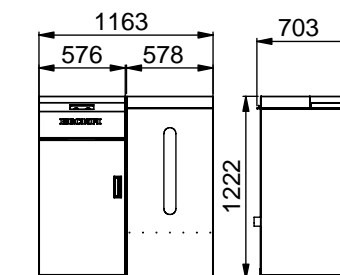

## HYDROBALTICA 27/34

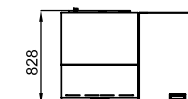
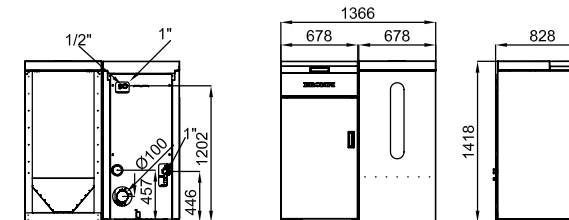





ACCESORIOS  
ACCESSORIES  
ACESSÓRIOS







# PANELES DECORATIVOS

# DECORATIVE PANELS PAINÉIS DECORATIVOS



✓ Elaborados en acero.  
✓ Acabados en pintura blanca o negra.

✓ Made of steel.  
✓ Finished in white or black paint.

✓ Fabricado em aço.  
✓ Acabado em pintura branca ou preta.



REF: 651-B x 1  
REF: 650-B x 1  
REF: 639-N x 1

Simulación con modelo Dama-BU  
Simulation with model Dama-BU  
Simulação com modelo Dama-BU



REF: 650-B x 1  
REF: 639-N x 1



REF: 639-N x 1



REF: 651-N x 1  
REF: 650-N x 3  
REF: 638-N x 1

Simulación con modelo Nina-MF  
Simulation with model Nina-MF  
Simulação com modelo Nina-MF



REF: 650-N x 2  
REF: 638-N x 1



REF: 638-N x 1

**COMBINE A SU GUSTO TODOS LOS PANELES DISPONIBLES PARA DECORAR SU ESTUFA.**

COMBINE YOUR DESIGN WITH ALL THE PANELS AVAILABLE TO DECORATE YOUR STOVE  
COMBINE AO SE GOSTO TODOS OS PAINÉIS DISPONÍVEIS PARA DECORAR A SUA SALAMANDRA

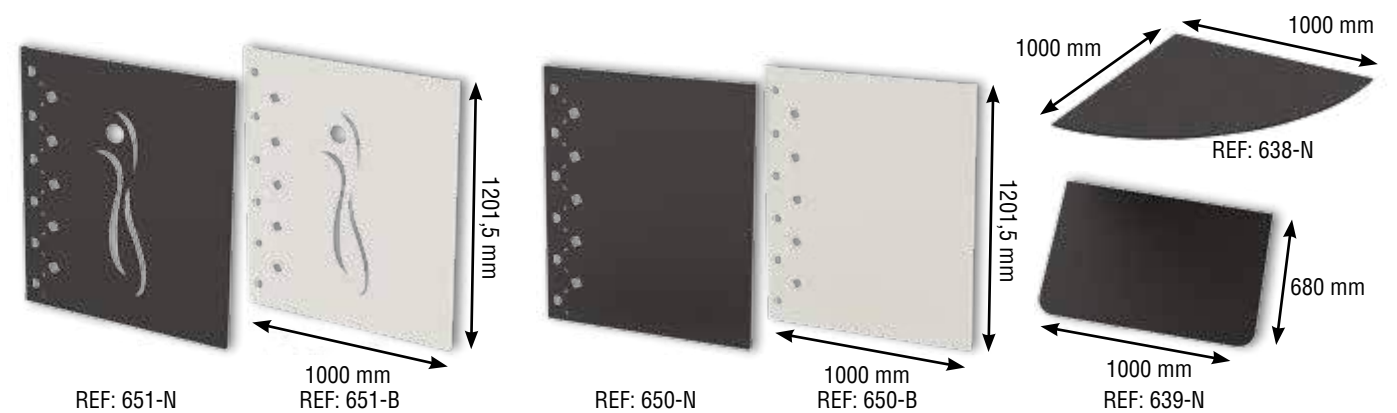



## DEPÓSITO PELLETT REF.372

Capacidad del depósito 25 Kg  
 Incluye ruedas de desplazamiento  
 Visor del nivel de carga  
 Tapa en madera de pino  
 Hopper capacity 25 Kg  
 Including scroll wheels  
 Load lever window  
 Pinewood cover  
 Capacidade do depósito 25 Kg  
 Inclui rodas  
 Indicação do nível de carga  
 Tapa de madeira de pinho

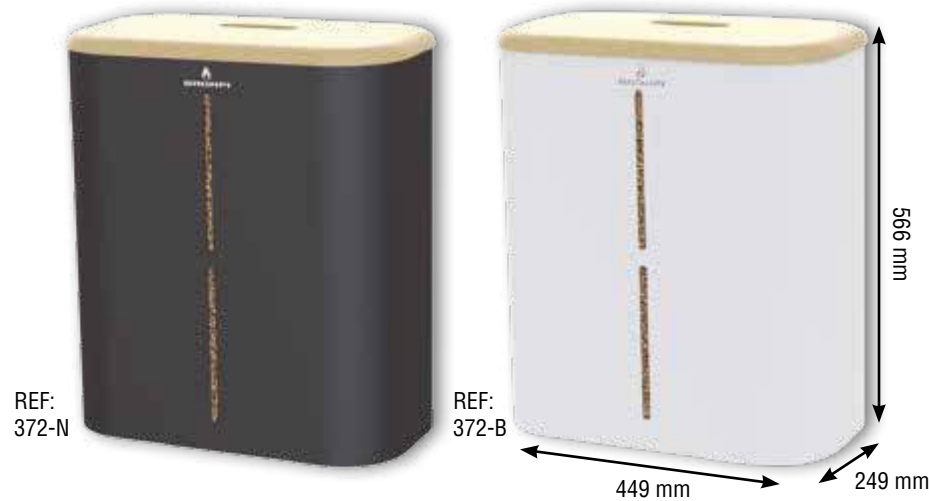

## DEPÓSITO PELLETT REF.373

Capacidad del depósito 37 Kg  
 Incluye ruedas de desplazamiento  
 Visor del nivel de carga  
 Tapa en madera de pino  
 Hopper capacity 37 Kg  
 Including scroll wheels  
 Load lever window  
 Pinewood cover  
 Capacidade do depósito 37 Kg  
 Inclui rodas  
 Indicação do nível de carga  
 Tapa de madeira de pinho

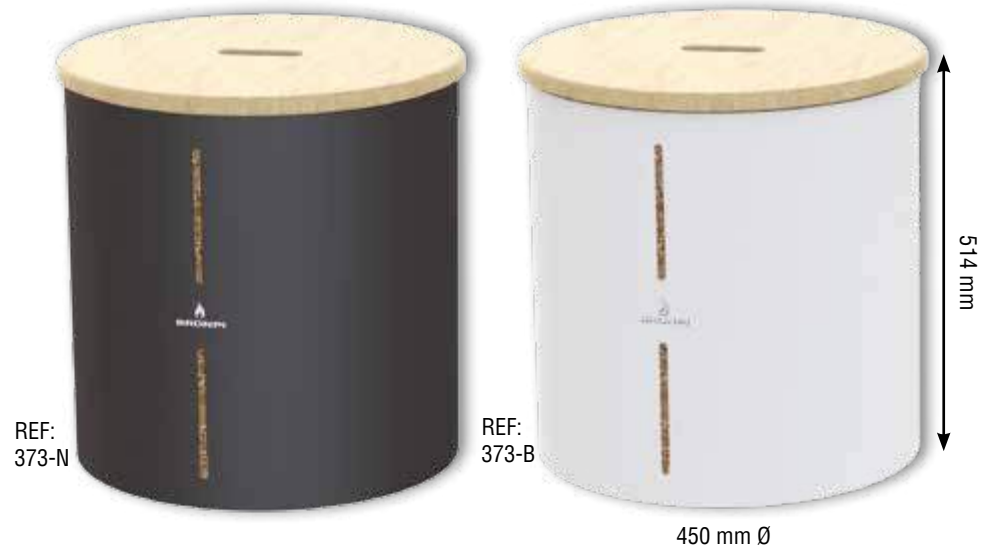

## DISPENSADOR PELLETT REF.375

1. Recargar el depósito con pellet.
  2. Tirar del accionador.
  3. Esperar que el recipiente extraíble esté lleno.
  4. Cerrar el accionador.
  5. Extraer el recipiente y recargar su estufa.
1. Refill the tank with pellet.
  2. Pull the actuator.
  3. Wait until the removable container is full.
  4. Close the actuator.
  5. Extract the container and load your stove.
1. Recarregar o reservatório com pellet.
  2. Puxe o atuador.
  3. Espere que o reservatório amovível esteja cheio.
  4. Fechar o atuador.
  5. Retire o reservatório e recarregar a sua salamandra.

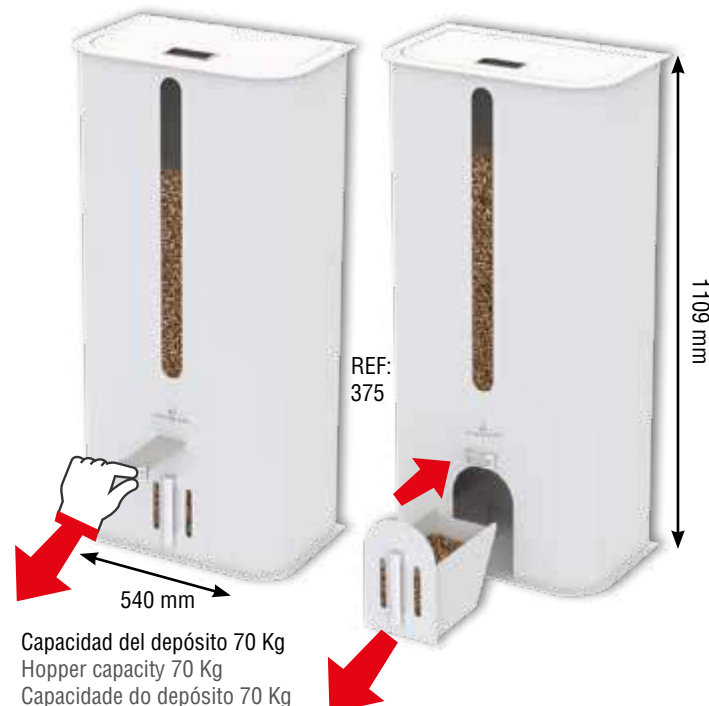

Capacidad del depósito 70 Kg  
 Hopper capacity 70 Kg  
 Capacidade do depósito 70 Kg

YouTube [youtube.com/BronpiCalefaccion](https://www.youtube.com/BronpiCalefaccion)

Vea el video explicativo del funcionamiento en nuestro canal de YouTube.  
 Watch the video explaining the operation on our YouTube channel.  
 Veja o vídeo explicativo do funcionamento no nosso canal do YouTube.

## KIT WIFI

KIT WIFI PARA CONTROL A TRAVÉS DE INTERNET

Con el KIT WIFI ahora es posible controlar su equipo a través de cualquier dispositivo con acceso a internet (ordenador, móvil, tablet...). A través de una aplicación, accederá a su estufa/caldera para conocer su estado, modificar la temperatura y potencia, encender y apagar, programar encendidos y apagados diarios, etc. Deberá disponer de internet wifi en el lugar donde instale el equipo.

WIFI CONTROL KIT THROUGH INTERNET

With the WIFI KIT it is now possible to control your stove through any device with internet access (computer, mobile, tablet...). Through an application, you will have access to your stove/boiler in order to know its status, change the temperature, turn it on and off, make daily schedules, etc. You must have a wireless connection in the place where the equipment is installed.

KIT WIFI PARA CONTROLE SOBRE A INTERNET

Com o KIT Wi-Fi agora é possível controlar a sua salamandra através de qualquer dispositivo com acesso à Internet (computador, celular, tablet...). Através de uma aplicação terá acesso à sua salamandra/caldeira para conhecer o seu estado, modificar a temperatura e potência, ligar e desligar, ligar e desligar a programação diária, etc. Você deverá ter acesso à Internet no lugar onde instalar a salamandra.



Ref. KIT WIFI 1: TINA, NINA, KIRA, ALBA, RITA, ZOE, AGATHA, ALEXIA, ALICIA, LETICIA, DAMA, PRINCESA, NOA, NEVA, NEVA EXTRA, ALICIA EXTRA, CLARA EXTRA, OLIVIA EXTRA, CLEO EXTRA, CLEO-NC, ABRIL EXTRA, CARMEN EXTRA, LOLA, CORAL, EVA, EVA-NC.



Ref. KIT WIFI 2: ELSA, CAROL MIXTA, BRENDA, BRENDA-E, PAULA, HYDROBOX, HYDROCONFORT.

## KIT GPRS

KIT GPRS PARA CONTROL VÍA SMS MÓVIL

Con el KIT GPRS ahora es posible controlar su equipo desde cualquier lugar del mundo. Con su teléfono móvil a través del envío de SMS podrá encender/apagar la estufa, modificar la temperatura y potencia y saber el estado de la estufa entre otras funciones. Ideal para todos los que desean instalar un equipo en su segunda vivienda, permitiendo encontrarse al volver un ambiente calefactado y confortable tras largos períodos de ausencia. Además, el equipo BioBronpi le responde con un SMS a su teléfono móvil que le permite asegurar la correcta operación. El KIT GPRS es una solución que le facilitará su día a día al coste mínimo de un SMS de texto.



GPRS KIT TO CONTROL TROUGHT SMS

Thanks to the GPRS KIT you can control your stove from anywhere in the world.

By sending an SMS with your mobile phone you will be able to ignite/turn off the stove, change the temperature and the power settings and know the status of the stove, as well as other features. It is the best choice for those who wish to install heating in their second home. Thus, when you arrive there, you can find a heated and comfortable home even after long periods of absence. What is more is that a BioBronpi stove will send you a SMS to your mobile phone in order to ensure proper operation. The GPRS KIT is a solution that will make your day-to-day tasks easier at the minimum cost of a text message.

KIT GPRS PARA CONTROLO VIA SMS MÓVIL

Com o KIT GPRS permite controlar o seu equipamento desde qualquer lugar no mundo. Com o seu telefone movel através do envio de um SMS poderá acender / apagar a estufa, modificar a temperatura e a potência e saber o estado da estufa entre outras funções. Ideal para todos os que desejam instalar um equipamento na sua segunda vivienda, permitindo encontrar um ambiente aquecido e confortavel após longos períodos de ausência. O equipamento BioBronpi responde com um SMS a um telefone móvel que permite assegurar a correcta operação. O KIT GPRS é uma solução que facilitará o seu dia a dia ao valor mínimo de um SMS de texto.

## KIT DE MOVILIDAD

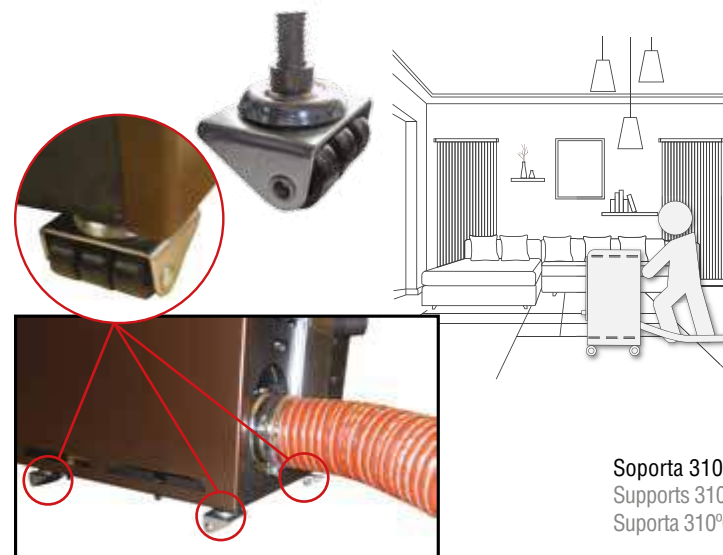

KIT DE MOVILIDAD: ¡Llévate tu estufa dónde quieras!

Ref.: KIT-M500 o KIT-M1000: Tubo Ø 80 mm en longitud 500 mm o 1000 mm + 4 ruedas.

Ref.: KIT-M500SR o KIT-M1000SR: Tubo Ø 80 mm en longitud 500 mm o 1000 mm

Compatible con modelos TINA, RITA, ZOE, KIRA, ALBA, NINA y BERTA.

MOVEMENT KIT: Take your stove wherever you want!

Ref.: KIT-M500 o KIT-M1000: Pipe Ø 80 mm with 500 mm or 1000 mm long + 4 wheels.

Ref.: KIT-M500SR o KIT-M1000SR: Pipe Ø 80 mm with 500 mm or 1000 mm long.

Compatible with models TINA, RITA, ZOE, KIRA, ALBA, NINA and BERTA.

KIT DA MOBILIDADE: Levar o seu fogão onde quer que você quer!

Ref.: KIT-M500 o KIT-M1000: Tubo Ø 80 mm com 500 mm ou 1000 mm de comprimento + 4 rodas.

Ref.: KIT-M500SR o KIT-M1000SR: Tubo Ø 80 mm com 500 mm ou 1000 mm de comprimento.

Compatível com modelos TINA, RITA, ZOE, KIRA, ALBA, NINA e BERTA.

Soporta 310° C.  
 Supports 310 °C.  
 Suporta 310°C







## CENTRALITA PE-130

## CONTROL UNIT PE-130 CENTRALINA PE-130

La centralita a distancia nos permite realizar un control sobre nuestra caldera/estufa en cada momento sin necesidad de estar frente al equipo. Se podría definir como un segundo display, a través del cual podremos acceder a todas y cada una de las funciones que posee nuestro equipo: encender/apagar, aumentar/disminuir la potencia o la temperatura, detección de alarmas....etc. Su utilización es similar al display que se incorpora en los modelos BioBRONPI.

The remote control unit allows us to control our boiler/stove at all times without necessity of being in front of the device. It could be defined as a second display, that gives access to all functions of the device: turn on/off, increase/decrease power or temperature, alarm detection, etc. It is very similar to the display integrated into all BioBRONPI models.

A centralina remota permite-nos controlar o nosso equipamento sem a necessidade de estar em frente ao mesmo. Pode ser considerado como um segundo display, através da qual poderemos aceder às mesmas funções que possui o equipamento: Acender / apagar; aumentar / diminuir a potencia ou a temperatura; verificar alarmes, etc. A sua utilização é similar à do display incorporado nos modelos BioBronpi.



## TERMOSTATO AMBIENTE T-AMB

### ROOM THERMOSTAT T-AMB | TERMOSTATO AMBIENTE T-AMB

Termostato de regulación manual que nos permite controlar el funcionamiento de nuestra caldera de forma instantánea en función de la temperatura ambiente deseada.

Termostato ambiente che permette il controllo del funzionamento della caldaia istantaneamente, a seconda della temperatura ambiente desiderata.

Termóstato de regulação manual que nos permite controlar o funcionamento da nossa caldeira de forma instantânea em função da temperatura ambiente desejada.



## CRONOTERMOSTATO CRONO-01

### CHRONO-THERMOSTAT CRONO-01 | CRONOTERMOSTATO CRONO-01

Termostato de regulación manual que nos permite controlar el funcionamiento de nuestra caldera combinando el funcionamiento de forma instantánea o bien realizando una programación horaria de funcionamiento en función de la temperatura ambiente deseada.

Adjustable thermostat that allows the control of operation of the boiler combining instant operation and scheduled programs of operation, depending on the desired room temperature.

Termóstato de regulação manual, que nos permite controlar o funcionamento da nossa caldeira combinando o funcionamento de forma instantânea, ou através de uma programação horária de funcionamento em função da temperatura ambiente desejada.



## VÁLVULA MOTORIZADA 3 VÍAS VAL-04

### MOTORIZED THREE-WAY VALV VAL-04 | VÁLVULA MOTORIZADA DE 3 VÍAS VAL-04

Dentro del circuito hidráulico de la caldera, la válvula de tres vías tiene dos posiciones de funcionamiento bien sea de calefacción o de ACS, dirigiendo el agua generada a uno u otro circuito en función la señal recibida por la caldera. Debemos tener en cuenta que el circuito de ACS tendrá prioridad sobre el de calefacción.

In the hydraulic circuit of the boiler, the three-way valve has two operation statuses be it of heating or sanitary hot water, directing the hot water generated to the one circuit or to the other depending on the signal received by the boiler. It is important to keep in mind that the sanitary hot water circuit has priority over the heating circuit

Dentro do circuito hidráulico da caldeira, a válvula de três vias tem duas posições de funcionamento, Aquecimento Central ou AQS, conduzindo a água quente produzida ao circuito desejado conforme o sinal recebido pela caldeira. Deveremos ter em atenção, que o circuito de AQS é prioritário sobre o circuito de Aquecimento Central.



## VÁLVULA TERMOSTÁTICA ANTICONDENSACIÓN

### ANTICONDENSATION THERMOSTATIC VALVE VÁLVULA TERMOSTÁTICA ANTICONDENSAÇÃO

### VAL-02 | VAL-03

La válvula permite mantener constante la temperatura del agua de retorno a la caldera en valor seleccionado de una temperatura de 55° C.

VAL-02 : válvula termostática anti-condensación de 3 x 1”

VAL-03 : válvula termostática anti-condensación de 3 x 1 ¼”

The valve keeps constant temperature of the water returned to the boiler in a selected value of temperature (55°C).

VAL-02 : anticondensation thermostatic valve, 3 x 1”

VAL-03 : anticondensation thermostatic valve, 3 x 1 ¼”

A válvula permite manter constante a temperatura da água de retorno à caldeira a uma temperatura de 55 °C.

VAL-02 : válvula termostática anti condensação de 3 x 1”

VAL-03 : válvula termostática anti-condensação de 3 x 1 ¼”



## CAJA DISTRIBUCIÓN DE CALOR HEAT DISTRIBUTION BOX | CAIXA DE DISTRIBUIÇÃO



Ventilador centrífugo con motor 220V / 0,4A / 1350 rpm  
Caja metálica en acero galvanizado  
Aislamiento acústico y térmico  
Termostato de regulación de 0°-90°  
Temperatura máxima de funcionamiento 200°.



Ventilador centrífugo Com motor 220V / 0,4A / 1350 rpm  
Caixa metálica em aço galvanizado  
Isolamento acústico e térmico  
Termostato de regulação de 0°-90°  
Temperatura máxima de funcionamento 200°

Centrifugal fan With motor 220V / 0,4A / 1350 rpm  
Metal box in galvanized steel  
Acoustic and thermal insulation  
Regulation thermostat of 0°-90°  
Maximum operating temperature of 200°

REF. B-400: 400 m3/h: 402 x 301 x 260 mm  
REF. B-600: 600 m3/h: 412 x 341 x 265 mm

## REJILLA SIMPLE SIMPLE GRILLE | GRELHA SIMPLE



80Ø REF. RP08-G: GRIS  
REF. RP08-B: BLANCO

## REJILLA REGULABLE ADJUSTABLE GRILLE | GRELHA AJUSTÁVEL



80Ø REF. RPR08-G: GRIS  
REF. RPR08-B: BLANCO

## REJILLA PROTECTORA CRISTAL REJILLA-PR GLASS PROTECTION GRILLE | GRELHA PROTETORA PARA VIDRO

Rejilla protectora para cristal elaborada en varillas de acero cromado. Sujeción al aparato mediante imanes móviles en distintas posiciones. Consulte modelos compatibles.

Protective grille for glass made of chromed steel rods. Fasten to the device by moving magnets in different positions. Check compatible models.

Grelha protetora para vidro, fabricada com hastes em aço cromado. Fixação do equipamento através de ímãs móveis em diferentes posições. Consulte modelos compatíveis.

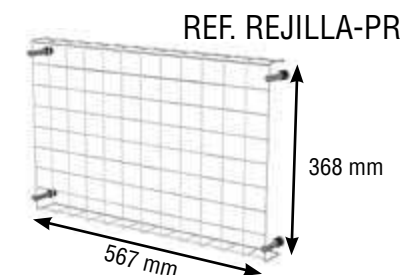

## DEPÓSITO 1000 LITROS 1000 LITRES TANK | DEPÓSITO 1000 LITROS

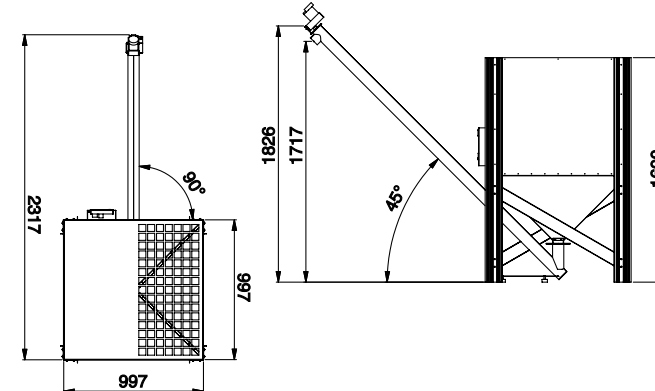

Depósito auxiliar de 1000 litros (650 Kg) de capacidad para ser conectado a calderas o termo-estufas. Con este depósito se incrementa la autonomía del modelo y el tiempo entre recarga de combustible.  
- Tolla de 1000 litros + tubo sin fin de 2 metros de longitud  
- Facilidad de instalación: tubo sin fin orientable 360°  
- Display LCD retro-iluminado para la programación y gestión del depósito  
- Alimentación automática a la caldera mediante sensores de nivel o programaciones diarias o semanales  
- Programación de aviso "combustible bajo"  
- Compatible con modelos HYDROPOLAR-21, HYDROARTICA-27, HYDROARTICA-34 y SERIE CARLOTA.

Auxiliary tank of 1000 litres (650 Kg) capacity to be connected to boilers or thermo-stoves. With this tank, the autonomy of the model and the time between refueling increases.

- Hopper of 1000 litres + auger pipe of 2 metres long  
- Easy to install: auger pipe adjustable 360°  
- Display LCD backlit for programming and managing the tank  
- Automatic feeding to the boiler using level sensor or daily or weekly schedule.  
- Programming warning "low fuel"  
- Compatible with models HYDROPOLAR-21, HYDROARTICA-27, HYDROARTICA-34 and CARLOTA.

Depósito auxiliar de 1000 litros (650 Kg) de capacidade para ser conectado a caldeiras ou salamandras a água. Com este depósito aumenta-se a autonomia do modelo e o tempo de recarga do combustível.

- Depósito de 1000 litros + tubo sem-fim com 2 metros de comprimento  
- Instalação fácil: tubo sem-fim orientável a 360°  
- Display LCD retro-iluminado para programação e gestão do depósito.  
- Alimentação automática da caldeira a través dos sensores de nível, ou através de programação diária ou semanal  
- Programação de aviso "combustível baixo"  
- Compatível com os modelos HYDROPOLAR-21, HYDROARTICA-27, HYDROARTICA-34 y SERIE CARLOTA.





# ACCESORIOS DE LIMPIEZA

## CLEANING ACCESSORIES | ACESSÓRIOS DE LIMPEZA



Ref. ASPIRADOR

Ref. 25

Ref. 30

Ref. 24

Ref. 29 10 mm  
Ref. 31 12 mm

Ref. 23-N

Ref. 21

Caja de 12 unidades.  
Box with 12 units.  
Caixa de 12 unidades.

Caja de 12 unidades.  
Box with 12 units.  
Caixa de 12 unidades.

## EXPOSITOR ACCESORIOS

## CLEANING ACCESSORIES ACESSÓRIOS DE LIMPEZA

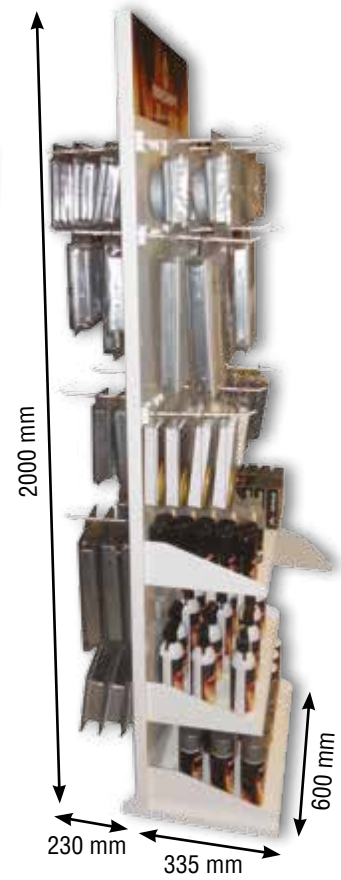
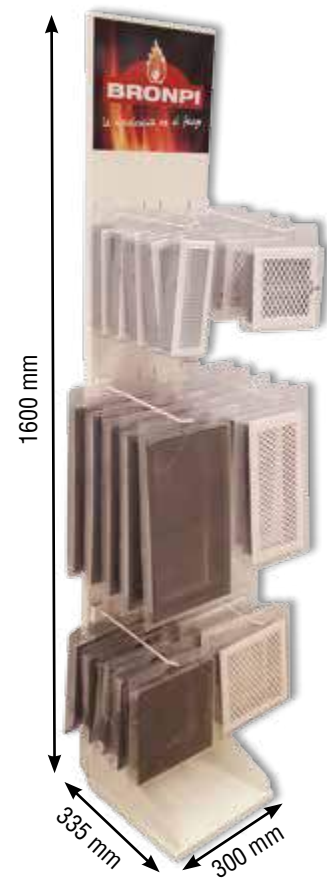

### EXPO-BRO

Regalo por la compra de accesorios de limpieza y/o rejillas por importe igual o superior a 300€ neto en factura.

Gift for the purchase of cleaning accessories and/or grilles for an amount equal to or higher than 300€ net in invoice.

Regalo por la compra de accesorios de limpieza y/o rejillas por importe igual o superior a 300€ neto en factura.

### EXPO-A

Regalo por la compra de accesorios de limpieza y/o rejillas por importe igual o superior a 600€ neto en factura.

Gift for the purchase of cleaning accessories and/or grilles for an amount equal to or higher than 600€ net in invoice.

Regalo por la compra de accesorios de limpieza y/o rejillas por importe igual o superior a 600€ neto en factura.

### EXPO-AG

Regalo por la compra de accesorios de limpieza y/o rejillas por importe igual o superior a 700€ neto en factura.

Gift for the purchase of cleaning accessories and/or grilles for an amount equal to or higher than 700€ net in invoice.

Presente pela compra de acessórios de limpeza e/ou grelhas por valor igual ou superior a 700€ líquido em factura.

### EXPO-AD

Regalo por la compra de accesorios de limpieza y/o rejillas por importe igual o superior a 800€ neto en factura.

Gift for the purchase of cleaning accessories and/or grilles for an amount equal to or higher than 800€ net in invoice.

Presente pela compra de acessórios de limpeza e/ou grelhas por valor igual ou superior a 800€ líquido em factura.





Ctra. Córdoba-Málaga, km 78,2 Nacional 331, Salida Autovía 62 Lucena Sur  
Telf. +34 957 50 27 50 / Fax +34 957 59 17 25  
Apartado de Correos 255  
14900 Lucena (Córdoba)  
e-mail: [bronpi@bronpi.com](mailto:bronpi@bronpi.com)  
[www.bronpi.com](http://www.bronpi.com)

**Síguenos en:**



@Bronpi



[facebook.com/bronicalefaccion](https://facebook.com/bronicalefaccion)



PREMIO ALAS

v160617

